

# STEL

## Railway Maintenance

# CATALOGUE

# 2019

**STEL** SPECIALISED  
TOOLS &  
EQUIPMENT LTD

1300 853 360 

[info@linklite.com.au](mailto:info@linklite.com.au) 

[www.linklite.com.au](http://www.linklite.com.au) 



# WELCOME

## DELIVERY

---

Next Day  
Next Day Before 10am  
Next Day Before 12noon  
Pallets  
Same Day Delivery  
Collections Welcome

All Delivery Prices Exclude VAT & Are Not Eligible For Discount

## PRICES

---

All Prices Exclude VAT

## PAYMENT METHODS

---



WE ALSO ACCEPT **CASH ON COLLECTION**

## YOUR DETAILS

Title:			
Company Name:			
Phone:	Fax:	Email:	
Registered Company Address:			
			Post Code:
Date Business Commenced:		Company Registration Number:	
Sole Proprietorship:	Partnership:	Limited:	Other:

## BUSINESS AND CREDIT INFORMATION

Primary Business Address:			
			Post Code:
How Long At Current Address:			
Phone:	Fax:	Email:	
Bank Name:			
Bank Address:			
			Post Code:
Sort Code:		Account Number:	

## BUSINESS/TRADE REFERENCES

Company Name:			
Address:			
			Post Code:
Phone:	Fax:	Email:	
Type of Account:			
Company Name:			
Address:			
			Post Code:
Phone:	Fax:	Email:	
Type of Account:			

## AGREEMENT

1. All invoices are to be paid 30 days from the date of the invoice.
2. Claims arising from invoices must be made within seven working days in writing.
3. By submitting this application, you authorise Specialised Tools & Equipment Ltd to make enquiries into the banking and business/trade references that you have supplied.

## SIGNATURE

Print Name:	Date:
Signature:	

## CONTENTS

### TRACK TOOLS

Tools For Use On Pandrol Fastening Systems	1,2,3
Track Tools	4
Rail Turning Bars & SHC and SCHWIHAG Bars & Points Handle	5
Spanners	6
Jack Handles	7
Pad Scrappers & Pot Dollys	8
Digging Bars, Chair Screws & Ferrulle Extractors	9
Crowbars	10
Insulated Ground Tools	11
Non Insulated Ground Tools	12
Hammers	13

### CUTTERS, AUGERS, BREAKERS

STEL Rail Cutters	14
Rotabroach Rail Cutters	15
Augers	16
Breakers	17

### SOCKETS

1" Inch Drive Sockets	18
1/2" Inch Drive Sockets	18
O - Rings	18
Retaining Pins	18
Socket Adaptors	18,19

### FUEL MANAGEMENT

20 Litre Fuel Cans	21,23
10 Litre Fuel Cans	21,23
5 Litre Fuel Cans	22,23
Safety Cans	22
Plastic Jerry Cans	22
Rigid Spouts	24
Flexible Spouts	24
No Spill Spouts	25
Plastic Containers	25

### SPILL MANAGEMENT

Absorbants	26,27
Plant Nappies	27

### SIGNAGE

Speed Boards	28
Indicator Boards	29
Tildawn, Warning Lights	30
Warning Boards	31,32

### OILS

Oils	33
------	----

### SPARES

Spark Plugs	34
Drive Belts	35

### ABRASIVES

Cutting Disc's	36
Grinding Stone's	36

### BATTERIES

Batteries	37
-----------	----



## CONTENTS

### PPE

Gloves	38
Track Workers PPE	39,40

### LIGHTING

Lucia Link Light	41
Plugs & Sockets	42
40 Watt Magnetic Work Light	43
27 Watt Magnetic Work Light	44

### CLAMPING & FASSETTAS

Emergency G - Clamp	45
Fishplates	45
Fassetta Clamps	46
Fassetta Bolts	46

### TRACK MEASURING

Digital Thermometer	47
Analogue Thermometer	47
Single Track Measuring Wheel	48
Dual Track Measuring Wheel	48

### WHEEL BARROW

Insulated Wheel Barrow	49
------------------------	----

### SMALL PLANT

Rail Handler	50-57
B - Type Trolley	58-62
Link Trolley	63-69
Trolley Ramps	70
Skate Basket	71-73
Impact Wrench	74-75
Rail Saw	76
Chainsaw	77,78
Chainsaw Spares	79,80
Bernard Engine	81
Bernard Engine Spares	82
Generators	83-85
Dust Suppression Water Bottle	86
Pump Bottle	86
STEL's Battery Powered Rail Drill	87,88
Magic Wand	89
Track Magnets	90
Lever Hoist & Clamps	91-98

# STEL

## SERIOUS ABOUT SERVICE

**Clarke**

**STIHL**

**DEWALT**

**STEL**  
TOOLS & CONSUMABLES

**DORMAN**

**STEL**  
TOOLS & CONSUMABLES

**HILTA**









**STANLEY**

**Makita**

**SIMPLEX**

**MC Electronics**  
Railway Safety Solutions

**TOOLS FOR USE ON PANDROL FASTENING SYSTEMS**

		
<b>Insulated Pandrol E Clip &amp; PR Clip Pan Puller</b>	<b>Insulated Pandrol E Clip Pan Setter</b>	<b>Insulated Pandrol E Plus Pan Puller</b>
<b>Part No; FIBTPCPL</b>	<b>Part No; FIBTPCST</b>	<b>Part No; FIBTEPPP</b>
		
<b>Insulated Pandrol Elastic Spike Extractor</b>	<b>Insulated Pandrol Fastclip Extractor</b>	<b>Insulated Pandrol Fastclip Installer</b>
<b>Part No; FIBTESEX</b>	<b>Part No; FIBTFCEXT</b>	<b>Part No; FIBTFCINT</b>
		
<b>Insulated Pandrol Fastclip Sleeper Lifter</b>	<b>Insulated Pandrol Pan Lock Pan Puller</b>	<b>Insulated Pandrol Rear Arch Extractor</b>
<b>Part No; FIBTFCSL</b>	<b>Part No; FIBT65</b>	<b>Part No; FIBTLP15177</b>

**TOOLS FOR USE ON PANDROL FASTENING SYSTEMS**



**Pandrol E Plus Pan Puller**

Part No; EPPP



**Pandrol E Plus Pan Puller**

Part No; LP12717



**Pandrol Fastclip & Vipa-Sp Installer**

Part No; FCINTVIPA



**Pandrol Fastclip Extractor**

Part No; FCEXT



**Pandrol Fastclip FE/FC & Vipa-Sp Extractor**

Part No; LP18679



**Pandrol Fastclip Installer**

Part No; FCINT



**Pandrol Fastclip Sleeper Lifter**

Part No; FCSL



**Pandrol FE/FC & Vipa-SP Installer**

Part No; LP18681



**Pandrol Pan Lock Puller**

Part No; PLPL

**TOOLS FOR USE ON PANDROL FASTENING SYSTEMS**

		
<p><b>Pandrol PR, E, E-Plus &amp; RE Clips Pan Setter</b></p>	<p><b>Pandrol Rear Arch Extension Tool</b></p>	<p><b>Pandrol RT60 Check Rail Installer</b></p>
<p><b>Part No; PCST</b></p>	<p><b>Part No; FCREARARCH</b></p>	<p><b>Part No; LP15561</b></p>
		
<p><b>Pandrol Type C For PR &amp; E-Clip Pan Puller</b></p>	<p><b>Pandrol Wear Gauge For Pan Puller Hook</b></p>	<p><b>Pandrol Spare Hook For E Plus Pan Puller</b></p>
<p><b>Part No; PCPL</b></p>	<p><b>Part No; PPHG</b></p>	<p><b>Part No; EPSHK</b></p>
		
<p><b>Pandrol Spare Bolt For Pan Puller</b></p>	<p><b>Pandrol Spare Hook For C &amp; D Pan Puller</b></p>	
<p><b>Part No; PPSHKB</b></p>	<p><b>Part No; PPSHK</b></p>	

**TRACK TOOLS**



**Insulated Concrete Sleeper Tongs**

Part No; FIBT104



**Insulated Steel Sleeper Tongs**

Part No; FIBTSLSTNG



**Insulated Timber Nips**

Part No; FIBT103



**Insulated Timber Sleeper Tongs Specifically Designed For NWR**

Part No; FIBTSHT002

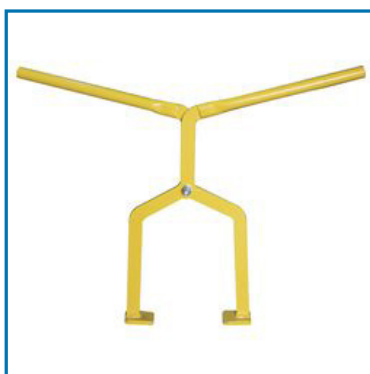

**Concrete Sleeper Tongs**

Part No; CT



**Rail Tongs**

Part No; RTG



**Steel Sleeper Tongs**

Part No; SLSTNG



**Timber Nips**

Part No; TNP



**Timber Sleeper Tongs Specifically Designed For NWR**

Part No; SHT002



**RAIL TURNING BARS & SHC & SCHWIHAG BARS & POINTS HANDLES**



**Insulated Rail Turning Bar  
Bull Head Rail & Flat  
Bottom**

Part No; FIBT54 (BH)  
; FIBT 55 (FB)

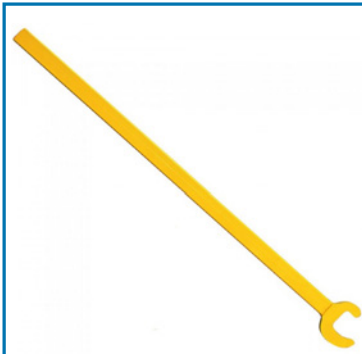

**Rail Turning Bar  
Bull Head Rail**

Part No; RTBBH

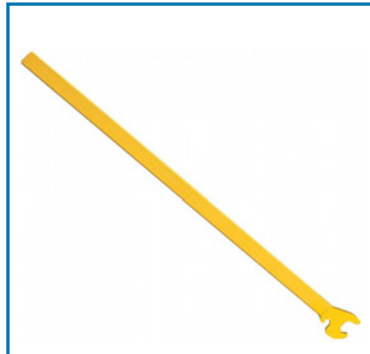

**Rail Turning Bar  
Flat Bottom**

Part No; RTBFB



**Points Machine Winding  
Handle Cranked Suits Style  
63 Points Machine**

Part No; RW19372



**STEL's Point Machine  
Winding Handle Cranked**

Part No; RW19370



**STEL's Point Machine  
Pump Handle Straight**

Part No; RW19371



**SHC De-Clipping Bar**

Part No; SHCBAR



**Insulated  
SHC De-Clipping Bar**

Part No; FIBTSHC



**SCHWIHAG Bar**

Part No; SWGB



**SPANNERS**



**15" Fishplate Nut Running Spanner**

Part No; FPSS

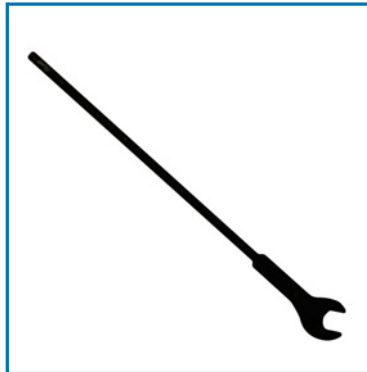

**30" Fishplate Nut Locking Spanner**

Part No; FPSL



**Insulated Bi-Square Fishplate Nut Spanner**

Part No; FIBT78A



**Insulated 1" T Drive Bar**

Part No; FIBTTBAR1



**Insulated Check Rail Spanner - 1-11/16" AF X 30"**

Part No; FIBT63



**Insulated Fishplate Spanner**

Part No; FIBT64



**Insulated Hook Switch Pole**

Part No; FIBT56

**Any Spanner Can Be Made To Order Just Contact The Sales Team!**

## JACK HANDLES



**Insulated  
1-1/4" Jack Handle**

**Part No; FIBT52**



**Insulated  
Hydraclaw Jack Handle**

**Part No; FIBT57**



**Insulated  
Hydramite Jack Handle**

**Part No; FIBT58**



**Insulated Pan Jack  
Jack Handle**

**Part No; FIBT51**



**Insulated  
Simplex 85A & Duff 516T  
Jack Handle**

**Part No; FIBT53**



**Insulated Simplex A17  
Jack Handle**

**Part No; FIBT59**



**Jack Handle  
Pan Jack, Toe Jack,  
Zwicky / Kenhi Handle**

**Part No; JACK1**

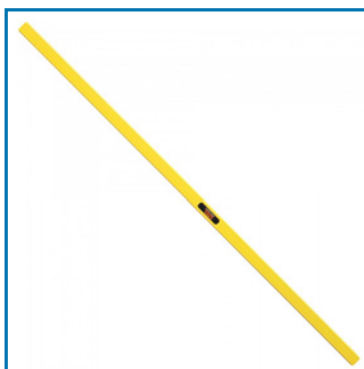

**Simplex A17  
Jack Handle**

**Part No; SIMPJH**



**Slewing Jack Handle Only  
CH65 Model**

**Part No; JACK2**

**PAD SCRAPERS & POT DOLLY'S**



**Insulated Pad Scraper**

Part No; FIBT35



**Large Pad Scraper**

Part No; PSCL



**Small Pad Scraper**

Part No; PSCS



**Pad Scraper Thin Blade  
300MM x 3MM Thick**

Part No; FIBT35

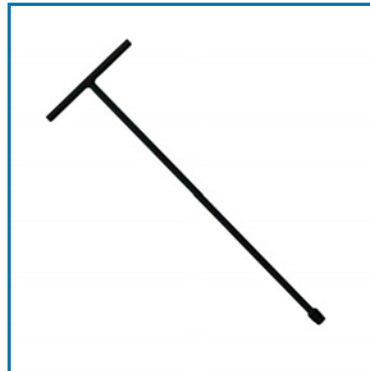

**All Steel Square Pot Dolly  
22MM For Wood**

Part No; POTDOLL22MMSQ

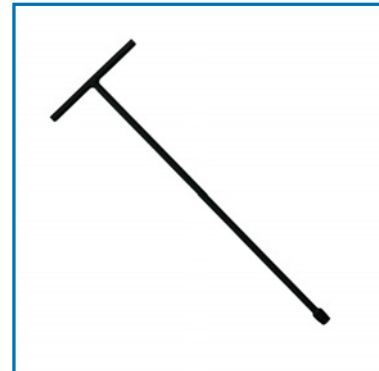

**All Steel  
Pot Dolly Hexagon 17MM**

Part No; POTDOLL17MM

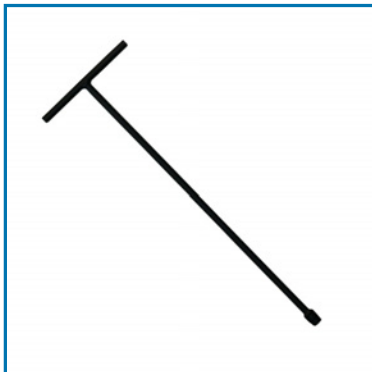

**All Steel  
Pot Dolly Hexagon 19MM**

Part No; POTDOLL19MM



**Insulated Pot Dolly Hexagon  
17MM For Concrete**

Part No; FIBT47



**Insulated Pot Dolly Square  
22MM For Wood**

Part No; FIBT46

**DIGGING BARS, CHAIR SCREWS & FERRULE EXTRACTORS**



**Insulated  
T - Handled Chair Screw  
1-1/8"**

**Part No; FIBT77**



**T - Handled Chair Screw  
1-1/8"**

**Part No; PDCONC**



**Heavy Duty 1.7m  
Digging Bar**

**Part No; DIGBAR**



**Insulated Digging Bar**

**Part No; FIBT70**



**All Steel Extractor Ferrule**

**Part No; FEX**



**Insulated Extractor Ferrule**

**Part No; FIBTFEX**

**CROWBARS**



Chisel & Point Crowbar

Part No; CBCPR



Heel & Point Crowbar  
1-1/8" Hex

Part No; CBHP



Heel & Point Crowbar  
(Round Shaft)

Part No; CBHPR



Insulated Chisel & Point  
Crowbar

Part No; FIBT23



Insulated Chisel End  
Crowbar

Part No; FIBT25



Insulated Heel & Point  
Crowbar

Part No; FIBT26



Insulated Heel End Crowbar

Part No; FIBT79



Insulated Point End Crowbar

Part No; FIBT24

10 TRACK TOOLS

**INSULATED SHOVELS TO BS 8020:2011**



**Square Mouth Shovel  
One Piece Handle**

**Part No; FIBT01R**



**Taper Mouth Shovel  
One Piece Handle**

**Part No; FIBT02R**



**Trenching Shovel  
One Piece Handle**

**Part No; FIBT03R**



**Rabbit Shovel  
One Piece Handle**

**Part No; FIBT05R**



**Newcastle Draining Shovel  
One Piece Handle**

**Part No; FIBT07R**



**Cable Laying Shovel  
One Piece Handle**

**Part No; FIBT08R**



**Clay Grafter Shovel  
One Piece Handle**

**Part No; FIBT09R**



**Round Mouth Shovel  
One Piece Handle**

**Part No; FIBT10R**



**Chipping Shovel Insulated**

**Part No; FIBT31**



**NON - INSULATED SHOVELS**



**Steel Taper Mouth Shovel**

Part No; SSTM



**Steel Round Mouth Shovel**

Part No; SSRM



**Steel Clay Grafter Shovel**

Part No; SSGT



**Steel Cable Laying Shovel**

Part No; SSCL



**Steel Newcastle Draining Shovel**

Part No; SSND

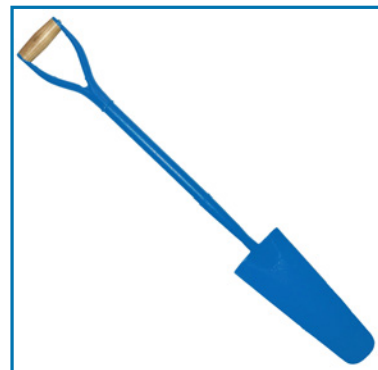

**Steel Rabbit Shovel**

Part No; SSRS



**Steel Trenching Shovel**

Part No; SSTS

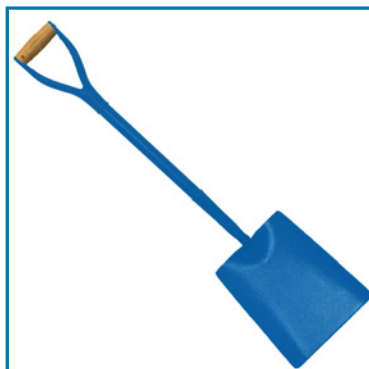









**Steel Square Mouth Shovel**

Part No; SSSM



## HAMMERS

		
Hickory Handle Keying Hammer - 10LB	Hickory Handle Keying Hammer - 7LB	Hickory Handle Sledge Hammer - 10LB
Part No; 10KH	Part No; 7KH	Part No; 10SH
		
Hickory Handle Sledge Hammer - 14LB	Hickory Handle Sledge Hammer - 7LB	Insulated Sledge Hammer - 10LB
Part No; 14SH	Part No; 7SH	Part No; FIBT61
		
Insulated Sledge Hammer - 14LB	Insulated Sledge Hammer - 7LB	Insulated Keying Hammer - 7LB OR 10LB
Part No; FIBT62	Part No; FIBT60	Part No; FIBT48 (10LB) FIBT49 (7LB)

**STEL RAIL CUTTERS**



Size;	Part No;
12MM	CRC12S
13MM	CRC13S
14MM	CRC14S
15MM	CRC15S
16MM	CRC16S
17MM	CRC17S
18MM	CRC18S
19MM	CRC19S
20MM	CRC20S
21MM	CRC21S
22MM	CRC22S
23MM	CRC23S
24MM	CRC24S

Size;	Part No;
25MM	CRC25S
26MM	CRC26S
27MM	CRC27S
28MM	CRC28S
29MM	CRC29S
30MM	CRC30S
31MM	CRC31S
32MM	CRC32S
33MM	CRC33S
34MM	CRC34S
35MM	CRC35S
36MM	CRC36S
37MM	CRC37S



Size;	Part No;
12MM	CRC12L
13MM	CRC13L
14MM	CRC14L
15MM	CRC15L
16MM	CRC16L
17MM	CRC17L
18MM	CRC18L
19MM	CRC19L
20MM	CRC20L
21MM	CRC21L
22MM	CRC22L
23MM	CRC23L
24MM	CRC24L

Size;	Part No;
25MM	CRC25L
26MM	CRC26L
27MM	CRC27L
28MM	CRC28L
29MM	CRC29L
30MM	CRC30L
31MM	CRC31L
32MM	CRC32L
33MM	CRC33L
34MM	CRC34L
35MM	CRC35L
36MM	CRC36L
37MM	CRC37L



Short Series	
Size;	Part No;
19MM	TCTR19S
22MM	TCTR22S
23MM	TCTR23S
25MM	TCTR25S
26MM	TCTR26S
28MM	TCTR28S
30MM	TCTR30S
32MM	TCTR32S
33MM	TCTR33S



Upon Enquiry Different Size Cutters May Be Available.

14 CUTTERS

## ROTABROACH RAIL CUTTERS



Size;	Part No;
13MM	SRCV130
13.5MM	SRCV135
14MM	SRCV140
15MM	SRCV150
17MM	SRCV170
18MM	SRCV180
19MM	SRCV190
20MM	SRCV200
21MM	SRCV210
22MM	SRCV220
24MM	SRCV240

Size;	Part No;
25MM	SRCV250
26MM	SRCV260
27MM	SRCV270
28MM	SRCV280
29MM	SRCV290
30MM	SRCV300
31MM	SRCV310
32MM	SRCV320
33MM	SRCV330
34MM	SRCV340
36MM	SRCV360



Size;	Part No;
13MM	SRCVL130
15MM	SRCVL150
19MM	SRCVL19
20MM	SRCVL200
21MM	SRCVL210
22MM	SRCVL220
24MM	SRCVL240
25MM	SRCVL250
26MM	SRCVL260
28MM	SRCVL280
30MM	SRCVL300

Size;	Part No;
32MM	SRCVL320
34MM	SRCVL340



Long Series	
Size;	Part No;
19MM	SCRWC190L
22MM	SCRWC220L
26MM	SCRWC260L
26MMXL	SCRWC260XL
28MM	SCRWC280L
28MMXL	SCRWC280XL
30MM	SCRWC300L
32MM	SCRWC320L

Short Series	
Size;	Part No;
13.5MM	SCRWC135
17MM	SCRWC170
19MM	SCRWC190
20MM	SCRWC200
21MM	SCRWC210
22MM	SCRWC220
24MM	SCRWC240
26MM	SCRWC260
27MM	SCRWC270
28MM	SCRWC280
30MM	SCRWC300
32MM	SCRWC320
34MM	SCRWC340

Upon Enquiry Different Size Cutters May Be Available.

**AUGERS**



Sleeper Drill Auger	
Size;	Part No;
10mm x 320mm to suit Cembre Sleeper Drill	CEM10
12mm x 320mm to suit Cembre Sleeper Drill	CEM12
13mm x 320mm to suit Cembre Sleeper Drill	CEM13
16mm x 320mm to suit Cembre Sleeper Drill	CEM16
17mm x 320mm to suit Cembre Sleeper Drill	CEM17
18mm x 320mm to suit Cembre Sleeper Drill	CEM18
19mm x 320mm to suit Cembre Sleeper Drill	CEM19
21mm x 320mm to suit Cembre Sleeper Drill	CEM21
22mm x 320mm to suit Cembre Sleeper Drill	CEM22



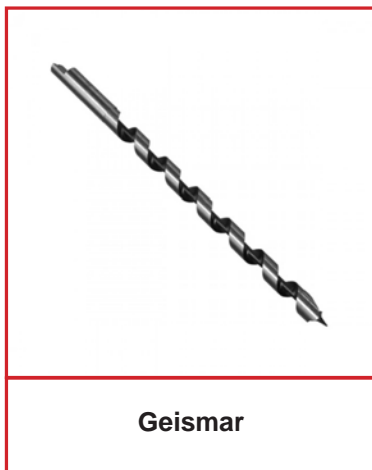

Sleeper Drill Auger	
Size;	Part No;
10mm x 240mm to suit Maxim Auger Attachment	MAX10
11mm x 240mm to suit Maxim Auger Attachment	MAX11
12mm x 240mm to suit Maxim Auger Attachment	MAX12
13mm x 240mm to suit Maxim Auger Attachment	MAX13
16mm x 240mm to suit Maxim Auger Attachment	MAX16
17mm x 240mm to suit Maxim Auger Attachment	MAX17
18mm x 240mm to suit Maxim Auger Attachment	MAX18
19mm x 240mm to suit Maxim Auger Attachment	MAX19
21mm x 240mm to suit Maxim Auger Attachment	MAX21
22mm x 240mm to suit Maxim Auger Attachment	MAX22



Sleeper Drill Auger	
Size;	Part No;
10mm x 290mm Geismar Type	GEIS10
16mm x 290mm Geismar Type	GEIS16
19mm x 290mm Geismar Type	GEIS19

16 AUGERS

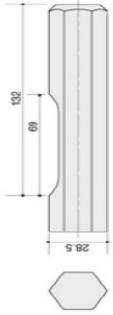
**BREAKER STEELS**

Picture	Part No	Description;	Fitment;
	GTL3039	Bosch 11304 Chisel 450mm/ 18"	Bosch 11304  
	GTL3036	Bosch 11304 Flat Point 450mm/ 18"	
	GTL3041	Bosch 11304 Chisel 3" Wide	

On Request We Are Able To Source Different Makes And Models Of Breaker Steels

Picture	Cat Ref;	Description;	Fitment;
	GTL2001 GTL2002	Point 380mm/ 15" 450mm/ 18"	1 1/4" Hexagon  
	GTL2008 GTL2009 GTL2010	Chisel 300mm/12" 380mm/ 15" 450mm/ 18"	
	GTL2017	Tarmac Cutter	
	GTL2019	Asphalt Cutter	
	GTL2020	18" Long Chisel (3")	
	GTL2022	Clay Spade	
	GTL2030	Tie Tamper	
	GTL2031	Tamping Shank	
	GTL2033	Tamping Pad	



**IMPACT SOCKETS**



1" Drive Impact Sockets  
Hexagon

Size;	Part Code;
16MM	SOC16MMX1
17MM	SOC17MMX1
18MM	SOC18MMX1
19MM	SOC19MMX1
20MM	SOC20MMX1
21MM	SOC21MMX1
22MM	SOC22MMX1
23MM	SOC23MMX1
24MM	SOC24MMX1
25MM	SOC25MMX1
26MM	SOC26MMX1

Size;	Part Code;
27MM	SOC27MMX1
28MM	SOC28MMX1
29MM	SOC29MMX1
30MM	SOC30MMX1
31MM	SOC31MMX1
32MM	SOC32MMX1
33MM	SOC33MMX1
34MM	SOC34MMX1
35MM	SOC35MMX1
36MM	SOC36MMX1
37MM	SOC37MMX1

Size;	Part Code;
38MM	SOC38MMX1
39MM	SOC39MMX1
40MM	SOC40MMX1
41MM	SOC41MMX1
42MM	SOC42MMX1
43MM	SOC43MMX1
44MM	SOC44MMX1
45MM	SOC45MMX1
46MM	SOC46MMX1
50MM	SOC50MMX1
55MM	SOC55MMX1



1/2" Drive Impact Sockets  
Hexagon

Size;	Part Code;
8MM	SOC8MMX12
10MM	SOC10MMX12
12MM	SOC12MMX12
13MM	SOC13MMX12
14MM	SOC14MMX12
15MM	SOC15MMX12
16MM	SOC16MMX12
17MM	SOC17MMX12
18MM	SOC18MMX12
19MM	SOC19MMX12
20MM	SOC20MMX12

Size;	Part Code;
21MM	SOC21MMX12
22MM	SOC22MMX12
23MM	SOC23MMX12
24MM	SOC24MMX12
25MM	SOC25MMX12
26MM	SOC26MMX12
27MM	SOC27MMX12
28MM	SOC28MMX12
29MM	SOC29MMX12
30MM	SOC30MMX12
32MM	SOC32MMX12

Size;	Part Code;
33MM	SOC33MMX12
36MM	SOC36MMX12
38MM	SOC38MMX12
39MM	SOC39MMX12
41MM	SOC41MMX12
42MM	SOC42MMX12
46MM	SOC46MMX12



1" Drive Bi-Square

Size;	Part Code;
1-1/8" X 1"	SOC118SQ
1-3/16" X 1"	SOC1316SQ
1-3/8" X 1"	SOC138SQ
1-5/16" X 1"	SOC1516SQ
1-11/16" X 1"	SOC11116SQ
28 x 21 mm	Part Code;
1"	SOCVOS
1/2"	SOCVOS12
3/4"	SOCOV34
1" 120MM	SOCVOSL
1/2" 90MM	SOCVOSL12
3/4" 90MM	SOCVOSL34



O - Rings

Size;	Part Code;
45MM	45MMOR
50MM	50MMOR
55MM	55MMOR
60MM	60MMOR



Retaining  
Pins

Size;	Part Code;
45MM	45MMPIN
50MM	50MMPIN
55MM	55MMPIN
60MM	60MMPIN

For Any Sockets That Aren't Listed Above Please Enquire With The Sales Team!

18 SOCKETS

**SOCKETS ADAPTORS**

		
<p>Socket Vossloh 28MM X 21MM X 1" Drive</p>	<p>Socket Vossloh 28MM X 21MM X 1/2" Drive</p>	<p>1/2" Drive X T50 Torx</p>
<p>Part No; SOCVOS</p>	<p>Part No; SOCVOS12</p>	<p>Part No; SOCT50X12</p>
		
<p>1" Drive X T70 Torx</p>	<p>3/4" Drive X T70 Torx</p>	<p>Socket Adaptor 3/4" Female X 1" Male</p>
<p>Part No; SOCT70X1</p>	<p>Part No; SOCT70X34</p>	<p>Part No; ADAP34FX1M</p>
		
<p>Socket Adaptor 1/2" Female X 1" Male</p>	<p>Socket Adaptor 1" Female X 1/2" Male</p>	<p>Socket Adaptor 1" Female X 3/4" Male</p>
<p>Part No; ADAP12FX1M</p>	<p>Part No; ADAP1FX12M</p>	<p>Part No; ADAP1FX34M</p>



**SOCKET ADAPTORS**



**Socket Adaptor  
3/4" Female X 1/2" Male**

Part No; ADAP34FX12M



**Socket Adaptor  
1" Male X 1" Male**

Part No; ADAP1MX1M

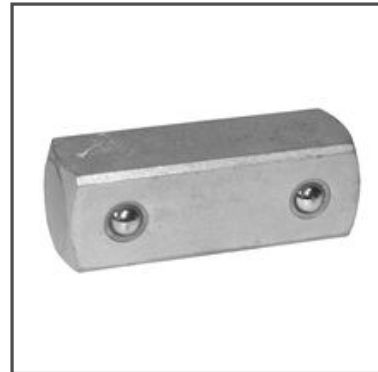

**Socket Connector  
3/4" Male X 3/4" Male**

Part No; ADAP34MX34M

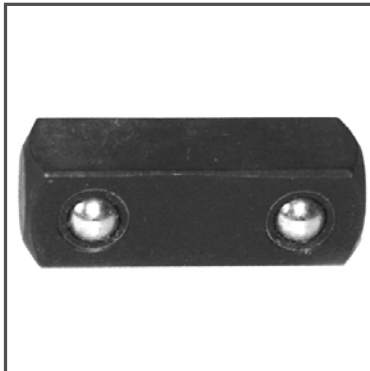

**Socket Adaptor  
1/2" Male X 1/2" Male**

Part No; ADAP12MX12M



**Socket Adaptor - Square  
1" Male X 3/4" Male**

Part No; SOCADMEF



**Universal Joint  
1" Male X 1" Female**

Part No; UNIVADAP



**Extension Bar  
1" Drive X 300MM**

Part No; EB300MM



**Extension Bar  
1/2" Drive X 300MM**

Part No; EB12X300



**Extension Bar  
1" Drive X 250MM**

Part No; EB250MM

20 SOCKETS

**JERRY CANS & SPOUTS**



20 Litre Jerry Can Black

Part No; JC20LB



20 Litre Jerry Can Green

Part No; JC20LG



20 Litre Jerry Can Red

Part No; JC20LR



20 Litre Jerry Can Yellow

Part No; JC20LY



10 Litre Jerry Can Black

Part No; JC10LB



10 Litre Jerry Can Green

Part No; JC10LG



10 Litre Jerry Can Red

Part No; JC10LR



10 Litre Jerry Can Yellow

Part No; JC10LY



5 Litre Jerry Can Black

Part No; JC5LB

**JERRY CANS & SPOUTS**



5 Litre Jerry Can Green

Part No; JC5LG



5 Litre Jerry Can Red

Part No; JC5LB



5 Litre Jerry Can Yellow

Part No; JC5LY



10 Litre Screw Top  
Jerry Can Red

Part No; JC10LRSCREW



10 Litre Screw Top  
Jerry Can Green

Part No; JC10LRSCREWG



10 Litre Screw Top  
Jerry Can Yellow

Part No; JC10LRSCREWY



10 Litre Jerry Can,  
Explosion Proof

Part No; JC10LEXY



5 Litre Jerry Can,  
Explosion Proof

Part No; JC5LEXY



5 Litre Plastic Jerry Can  
Black

Part No; PJC5LB

**JERRY CANS & SPOUTS**

		
<b>20 Litre Jerry Can Blue</b>	<b>20 Litre Jerry Can Green Screw Top</b>	<b>20 Litre Jerry Can Black Screw Top</b>
<b>Part No; 300047</b>	<b>Part No; 300033</b>	<b>Part No; 300034</b>
		
<b>20 Litre Jerry Can Red Screw Top</b>	<b>20 Litre Jerry Can Yellow Screw Top</b>	<b>10 Litre Jerry Can Black Screw Top</b>
<b>Part No; 300035</b>	<b>Part No; 300036</b>	<b>Part No; 300037</b>
		
<b>10 Litre Jerry Can Green Screw Top</b>	<b>10 Litre Jerry Can Red Screw Top</b>	<b>10 Litre Jerry Can Yellow Screw Top</b>
<b>Part No; 300038</b>	<b>Part No; 300039</b>	<b>Part No; 300040</b>

**JERRY CANS & SPOUTS**



5 Litre Plastic Jerry Can  
Green

Part No; PJC5LG



5 Litre Plastic Jerry Can  
Red

Part No; PJC5LR



Jerry Can Rigid Spout  
Green

Part No; JCFSRG



Jerry Can Rigid Spout  
Black

Part No; JCFSRB



Jerry Can Rigid Spout  
Red

Part No; JCFSRR



Jerry Can Rigid Spout  
Yellow

Part No; JCFSRY



Jerry Can Flexible Spout  
Black

Part No; JCPSFB



Jerry Can Flexible Spout  
Green

Part No; JCPSFG



Jerry Can Flexible Spout  
Yellow

Part No; JCPSFY

**JERRY CANS & SPOUTS**



**Jerry Can Flexible Spout  
Red**

**Part No; JCSFR**



**No Spill Fuel Spout  
Green**

**Part No; 300008**



**No Spill Fuel Spout  
Yellow**

**Part No; 300007**



**No Spill Fuel Spout  
Black**

**Part No; 300009**



**Flexible Black Spout**

**Part No; 300046**



**5 Ltr Plastic Container  
C/W Cap**

**Part No; BOT5L**



**10 Ltr Plastic Container  
C/W Cap**

**Part No; BOT10L**



**20 Ltr Plastic Container  
C/W Cap**

**Part No; BOT20L**



**ABSORBENTS**



**Absorbent Pads Lightweight  
500MM X 400MM Qty 200**

**Part No; G65940**



**Absorbent Pads Heavyweight  
500MM X 400MM Qty 100**

**Part No; G65935**



**Absorbent Rolls  
Heavy Weight**

**Part No; G65945**



**Absodan Absorbent  
Granules 20Ltr**

**Part No; G65982**



**Isol8 Organic Absorbent  
Bag 1.3Kg**

**Part No; G65975**



**Multi-Zorb Absorbent  
Granules 20Ltr**

**Part No; G65980**



**Spill Kit, Emergency Oil,  
Vinyl Bag, 50 Ltr**

**Part No; SK500**



**Spill Kit, Mini, Oil Only, 10 Ltr**

**Part No; VC683**



**Spill Kit, Emergency,  
Maintenance, Vinyl Bag,  
50 Ltr**

**Part No; SK500**

**26 SPILL MANAGEMENT**



**ABSORBENTS**



**Plant Nappy Small**  
685MM X 500MM

Part No; PNS



**Plant Nappy Medium**  
1000MM X 685MM

Part No; PNM



**Plant Nappy Large**  
2000MM X 1370MM

Part No; PNL



**Plant Nappy Liner Small**

Part No; PNSL



**Plant Nappy Liner Medium**

Part No; PNML



**Plant Nappy Liner Large**

Part No; PNLL



**Oil Spill Sheets Qty 200**  
500MM x 400MM

Part No; H0425040



**Absorbent Socks Universal**  
75MM x 1.2M Qty 2

Part No; G65950



**Spill Control Kit 30 Litre**  
Universal

Part No; G65955

**SPEED BOARDS**



Speed;	Part No;	Description;
5 Mph	TSR0105	Speed Board, 5 Mph, 390mm X 390mm
10 Mph	TSR0110	Speed Board, 10 Mph, 390mm X 390mm
15 Mph	TSR0115	Speed Board, 15 Mph, 390mm X 390mm
20 Mph	TSR0120	Speed Board, 20 Mph, 390mm X 390mm
25 Mph	TSR0125	Speed Board, 25 Mph, 390mm X 390mm
30 Mph	TSR0130	Speed Board, 30 Mph, 390mm X 390mm
35 Mph	TSR0135	Speed Board, 35 Mph, 390mm X 390mm
40 Mph	TSR0140	Speed Board, 40 Mph, 390mm X 390mm
45 Mph	TSR0145	Speed Board, 45 Mph, 390mm X 390mm
50 Mph	TSR0150	Speed Board, 50 Mph, 390mm X 390mm
55 Mph	TSR0155	Speed Board, 55 Mph, 390mm X 390mm
60 Mph	TSR0160	Speed Board, 60 Mph, 390mm X 390mm
65 Mph	TSR0165	Speed Board, 65 Mph, 390mm X 390mm
70 Mph	TSR0170	Speed Board, 70 Mph, 390mm X 390mm
75 Mph	TSR0175	Speed Board, 75 Mph, 390mm X 390mm
80 Mph	TSR0180	Speed Board, 80 Mph, 390mm X 390mm
85 Mph	TSR0185	Speed Board, 85 Mph, 390mm X 390mm
90 Mph	TSR0190	Speed Board, 90 Mph, 390mm X 390mm
95 Mph	TSR0195	Speed Board, 95 Mph, 390mm X 390mm
100 Mph	TSR0100	Speed Board, 100 Mph, 390mm X 390mm
125 Mph	TSR01125	Speed Board, 125 Mph, 390mm X 390mm

**TSR / ESR Signboard Board Supports System Track Mounted  
Signs / Emergency Indicator Suitable For Line Speeds Up To  
125 MPH**

**Part No; FTESR001**

**INDICATOR BOARDS**

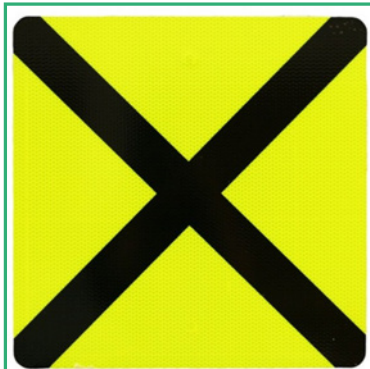

**Cancelling Indicator Board**  
390mm x 390mm

Part No; TSR06

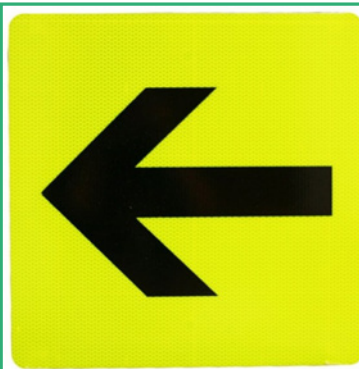

**Directional Indicator Board**  
390mm x 390mm

Part No; TSR04



**Spate Indicator Board**  
390mm x 390mm

Part No; TSR05

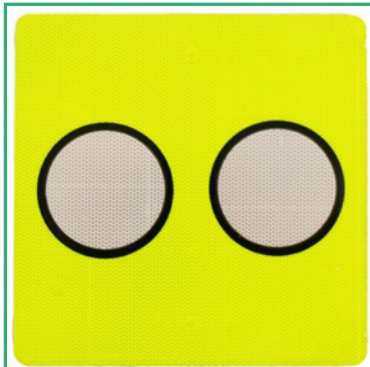

**Temporary Speed Restriction Board**  
390mm x 390mm

Part No; TSR21A



**Termination Indicator Board**  
390mm x 390mm

Part No; TSR07

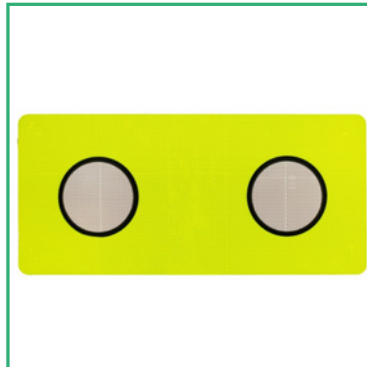

**Bullseye Temporary Speed Restriction Board**  
800mm x 300mm

Part No; TSR02

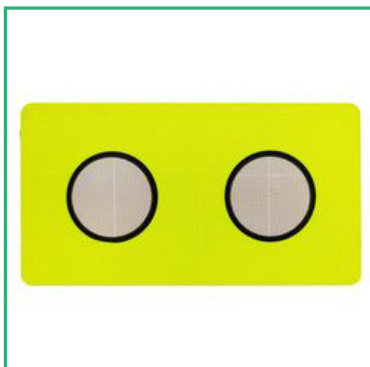

**Bullseye Temporary Speed Restriction Board**  
560mm x 300mm

Part No; TSR02C

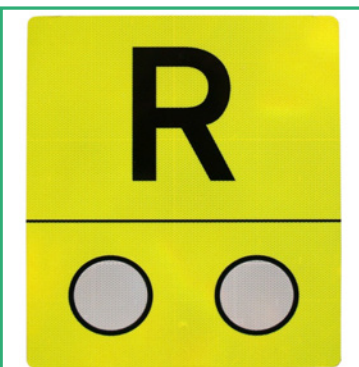

**Repeater Warning Temporary Speed Board**  
560mm x 660mm

Part No; TSR08A

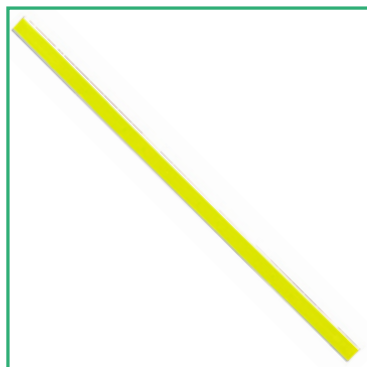

**Non Conductor Board Post**  
50mm x 50mm x 1800mm

Part No; TSR1418



**WARNING BOARDS & LIGHTS**



**Tildawn Light,  
Red Lens,  
Solid And Flashing**

Part No; TILDAWN



**Tildawn Light,  
Blue Lens,  
Solid And Flashing**

Part No; TILDAWNB



**Tildawn Light,  
Red Solid Comes Fitted With  
A Rail Clamp**

Part No; TILDAWNRC



**Red Led Warning Light**

Part No; REDLED



**Blue Led Warning Light**

Part No; BLUELED



**Amber Led Warning Light**

Part No; AMBERLED



**Lantern Battery**

Part No; LANTBAT

**Batteries Are Not Included With The Till Dawn Lights.  
The Till Dawns Require 2 x LANTBAT For Use.**

**WARNING BOARDS & LIGHTS**



**Early Warning  
Mini Eros Board**

**Part No; EROS**



**Early Warning  
Mini Eros Board  
Free Standing**

**Part No; EROSMC**



**Mce Eros Battery Pack**

**Part No; MCE1632**



**Battery Pack Plastic  
Case Only For Mini Eros  
Board**

**Part No; MCE1656**



**Led Mk11 Marker Board**

**Part No; 20039505**



**Mce Compact Worksite  
Marker Board**

**Part No; MCE1402**



**Mk11 Marker Board  
Possession Limit Board  
Switch Assembly**

**Part No; 54000089**



**Mk11 Marker Board  
Pcb Assembly Bottom**

**Part No; 54000091**



**Mk11 Marker Board  
Thief Proof Bolt  
M6 x 91mm**

**Part No; 54003082**

**WARNING BOARDS & LIGHTS**



Amber Lense Kit For Mk11 Marker Board ( C/W Fasteners)

Part No; 54037131



Red Lense Kit For Mk11 Marker Board ( C/W Fasteners)

Part No; 54037130



Mk11 Marker Board Label - Engineers Supervisors Area Red

Part No; 54038002



Mk11 Marker Board Label - PICOP Amber

Part No; 54038003



Led Stop Possession Limit Board

Part No; MCE306



Led Stop Possession Limit Board With Rail Clamp

Part No; MCEPLB205STk



Led Possession Limit Board

Part No; 5707990



OILS

Part No;	Description;	Size;
OIL1SYN	Two Stroke Fully Synthetic Oil	100ML
OIL1	Two Stroke Semi-Synthetic Oil	100ML
OIL18	3 In 1 Oil Drip Applicator	100ML
OIL14	WD-40 Spray	100ML
OIL19	3 In 1 Oil Drip Applicator	200ML
OIL23	3 In 1 Spray	200ML
OIL15	WD-40 Spray	200ML
OIL31	3 In 1 Ptfе Aerosol Spray	250ML
OIL22	3 In 1 High Performance Lubricant	400ML
OIL20	3 In 1 Penetrant Spray	400ML
OIL25	3 In 1 Silicone Lubricant	400ML
X61740	Force Chain Lube Spray [6 Pk]	400ML
X61775	Force Penetrating Fluid [6 Pk]	400ML
OIL2	WD-40 Smart Straw Spray	450ML
OIL16	WD-40 Spray	450ML
OIL29	WD-40 Spray	600ML

Part No;	Description;	Size;
OIL32C	Fully Synthetic Engine Oil 10W40	20L
OIL34	Hydraulic Grade T10 Oil	20L
OIL37A	Hydraulic Grade T15 Oil	20L
OIL42	Hydraulic Grade T32 Oil	20L
OIL47	Hydraulic Grade T37 Oil	20L
OIL33	Hydraulic Grade T46b Oil	20L
OIL32B	Motor Oil 10W30	20L
OIL24	Sae 30 Engine Oil	20L
OIL32	Semi-Synthetic Engine Oil 10W40	20L
OIL32A	Semi-Synthetic Engine Oil 15W40	20L
OIL4B	Soluble Semi-Synthetic Cutting Oil	20L

Part No;	Description;	Size;
OIL6	Anti-Fling Chainsaw Oil	1L
502 51 19-01	Husqvarna Chainsaw Oil [Genuine]	1L
OIL5	Sae 30 Engine Oil	1L
OIL4C	Semi-Synthetic Cutting Oil	1L
OIL35	Transformer Non Conductive Oil	1L
OIL1C	Two Stroke SuperWW Oil	1L

Part No;	Description;	Size;
OIL28	Anti-Fling Chainsaw Oil	5L
OIL43	Gear Oil 80W90	5L
OIL48	Heavy Duty De-Greaser	5L
502 51 19-05	Husqvarna Chainsaw Oil [Genuine]	5L
OIL37	Hydraulic Grade T15 Oil	5L
OIL33A	Hydraulic Grade T46b Oil	5L
OIL38	Indigear 60/80 Ep68 Oil	5L
OIL21	Sae 30 Engine Oil	5L
OIL4	Soluble Semi-Synthetic Cutting Oil	5L
OIL7	Two Stroke Oil	5L
OIL12	WD-40 Value Pack With Spray Bottle	5L



SPARK PLUGS



Part Code	Description
B2LM	NGK SPARK PLUG
B6HS	NGK SPARK PLUG
B6S	NGK SPARK PLUG
BCPR5ES	NGK SPARK PLUG
BCPR6ES	NGK SPARK PLUG
BCPR7ES	NGK SPARK PLUG
BCR8ES	NGK SPARK PLUG
BKR5E	NGK SPARK PLUG
BKR5EK	NGK SPARK PLUG
BM6A	NGK SPARK PLUG
BM7A	NGK SPARK PLUG
BMR4A	NGK SPARK PLUG
BMR6A	NGK SPARK PLUG
BP5ES	NGK SPARK PLUG
BP6ES	NGK SPARK PLUG
BPM6A	NGK SPARK PLUG
BPM6F	NGK SPARK PLUG
BPMR4A	NGK SPARK PLUG



Part Code	Name
BPMR6A	NGK SPARK PLUG
BPMR7A	NGK SPARK PLUG
BPMR8Y	NGK SPARK PLUG
BPR4ES	NGK SPARK PLUG
BPR5ES	NGK SPARK PLUG
BPR5HS	NGK SPARK PLUG
BPR6ES	NGK SPARK PLUG
BPR6HS	NGK SPARK PLUG
BR6HS	NGK SPARK PLUG
CMR4A	NGK SPARK PLUG
CMR5H	NGK SPARK PLUG
CMR6A	NGK SPARK PLUG
CMR6H	NGK SPARK PLUG
CMR7H	NGK SPARK PLUG
CR5HS	NGK SPARK PLUG
CR5HSB	NGK SPARK PLUG
CR9EH9	NGK SPARK PLUG



Part Code	Name
RCJ6Y	CHAMPION SPARK PLUG
RCJ7Y	CHAMPION SPARK PLUG
RCJ8	CHAMPION SPARK PLUG
RL86C	CHAMPION SPARK PLUG



34 SPARES

**DRIVE BELTS**

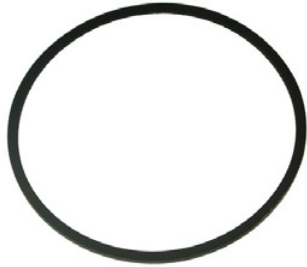

Truemeter Rail Measure  
Drive Belt

Part No; 102167-01



Kubota Rtv900 Wedge  
Drive Belt

Part No; 17594-97010

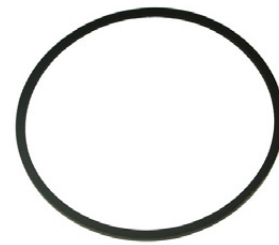

Husqvarna Drive Belt

Part No; 506 07 05-07



Husqvarna K650 Drive Belt  
[Non Oem]

Part No; BELT02



Husqvarna K750, K760 Drive  
Belt [Non Oem]

Part No; BELT03



Stihl Ts410 Drive Belt  
[Non Oem]

Part No; BELT05



Timberwolf Drive Belt  
[Non Oem]

Part No; BELT06



Geismar Mp12 Drive Belt  
[Non Oem]

Part No; UKG00923



Geismar Mp12 Toothed  
Drive Belt [Non Oem]

Part No; UKG00923A

CUTTING DISCS & GRINDING STONES

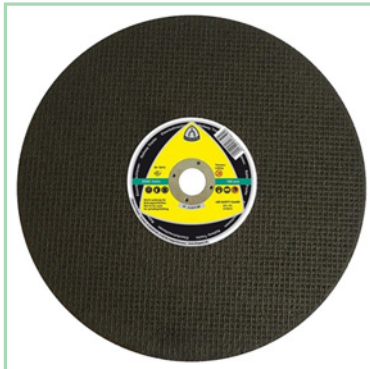

14" Inch Klingspor Rail Cutting Disc

Part No; KDISC14



16" Inch Klingspor Rail Cutting Disc

Part No; KDISC16



Rail Disc Carrying Bag

Part No; KDISCBAG

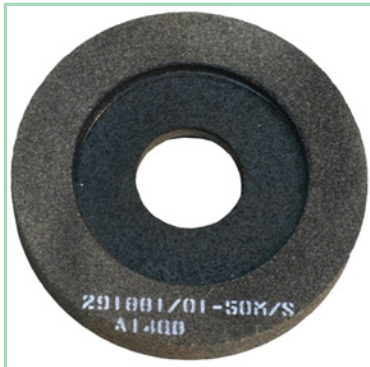

Replacement Geismar Mc3 Frog Stone

Part No; ADISCFROG



Replacement Geismar Mp12 Grinding Stone

Part No; MP12STONE

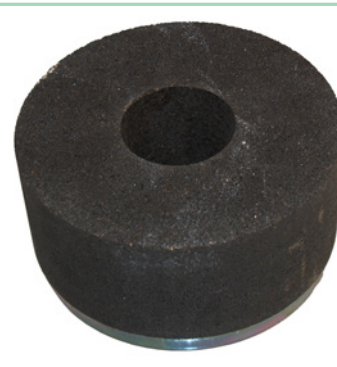

Cup Stone To Suit Geismar Mv3 Grinder

Part No; ADISCMV3



14" Inch Tyrolit Rail Cutting Disc

Part No; TDISC14



16" Inch Tyrolit Rail Cutting Disc

Part No; TDISC16



Diamond Blade, Vacuum Brazed 400mm x 20mm Bore

Part No; DPVB

Upon Enquiry Other Disc / Cutting Stones May Be Sourced!

36 ABRASIVES



## BATTERIES

Part No;	Part Description;
400010	Varta Gel Filled Battery To Suit Wacker Plate D52
508901	Varta 12V 8.6Ah Motorcycle Battery
BATT663	Energy 663 Greenmech Chipper 12V 110 Ah 680 CCA Battery
BATTI5	Varta Battery 15 Greenmech Chipper 12V 110Ah 680 CCA
G2	Varta Battery G2 12V 20Ah
VARTA	Varta Anti-Vibration, Anti-Spill 815 Cranking Amps, 50Ah
VARTA049	Tower Light Battery 45Ah 12V (MOSA 6000SX/GS)
VARTA1	Varta Battery D24, 60Ah, 12V
VARTA10	Varta D59 Battery 12V, 60Ah 540CCA Suits TL90 Light Tower
VARTA3	Varta Battery Blue Dynamics E24, 70Ah, 12V Suits Mk4, TL90
VARTA6	Varta Battery 12V, 44Ah (VTI Tower Light / Timberwolf Chippers) Tw4210
VARTA8	Varta 508901 Battery 12V 8Ah 150A
VARTA9	Varta Battery Heavy Duty Marine 140Ah 12V
LANTBAT	Lantern Battery NX Zinc 7Ah, 6V
ARCBAT	Arcgen Battery Welder Gen 8Ah, 12V YTX9-BS
EROSMC	Mini Eros Board Early Warning Battery Only
700013	20 Watt Battery Light
MCE1632	Battery Pack For Mini Eros Board
4932451245	Milwaukee M18 9.0Ah Red Lithium-Ion Battery

Upon enquiry other batteries may be able to be sourced



**GLOVES**



**Cut Level 5 Safety Gloves  
M, L, XL, XXL**

**Part No; CUT5GLOVES**



**Dipped Nitrile Grip Gloves  
L, XL**

**Part No; GLOVE41**



**Disposable Black Nitrile  
Gloves M, L, XL**

**Part No; Disposable Black  
Nitrile Gloves**



**Disposable Blue Nitrile  
Gloves S, M, L, XL**

**Part No; Disposable Blue  
Nitrile Gloves**

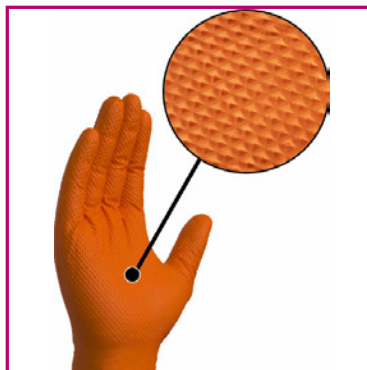

**Disposable Orange Nitrile  
Grip Gloves M, L, XL**

**Part No; Disposable Orange  
Nitrile Grip Gloves**



**Disposable Powder Free  
Nitrile Gloves - Box Of 100**

**Part No; Disposable Powder  
Free Nitrile Gloves**



**Grey Pu Palm Coated  
Gloves. S, M, L, XL**

**Part No; GLOVE40**



**Palm Coated Orange Gloves  
L, XL**

**Part No; Palm Coated  
Orange Gloves**



**Thermo Star Gloves  
M, L, XL**

**Part No; GLOVE39**



**TRACK WORKERS PPE**



**Chainsaw Forestry Helmet**

Part No; 562413



**Chainsaw Safety Gaiters**

Part No; RWCH005



**Chainsaw Safety Gloves (Large)**

Part No; GLOVE8



**Hi-Vis Chainsaw Trousers (XL)**

Part No; NR011



**Hi-Vis Quick Release Rucksack**

Part No; RSACKHIVISQR



**Hi-Vis Orange Thinsulate Balaclava With Ear Mesh**

Part No; THBOR



**Cut Resistant Sleeves**

Part No; SLEEVE



**Pura-Fit Disposable Earplugs 36Db - 20 Pairs**

Part No; C23530



**Red Ear Defenders**

Part No; EARDEFEND

**TRACK WORKERS PPE**



**Pura - Band Banded Ear Plugs 22DB (2PC)**

**Part No; C23520**



**16" Leather Gaiters / Spats**

**Part No; SPAT**



**60 Litre Heavy Duty Orange Nylon Kit Bag**

**Part No; KITBAG**



**Blue Canvas Tool Bag**

**Part No; 400095**



**Elasticated Safety Goggles**

**Part No; GOG1**



**Boston Safety Spectacles**

**Part No; BBBS**



**Florida Safety Spectacles With Grey Lens**

**Part No; BBFSS2GY**



**Pan View Clear Safety Spectacles**

**Part No; SAFESPEC**



**Uvex Silv-Air Valved Dust Mask Ffp3 (15 Pack)**

**Part No; MASK3**

# AUSTRALIAN DISTRIBUTOR



Contact Michelle King on:

1300 853 360

[info@linklite.com.au](mailto:info@linklite.com.au)

[www.linklite.com.au](http://www.linklite.com.au)

**PLUGS & SOCKETS**



**110V 16Amp Plug**

**Part No; PLUG1**



**110V 16Amp Socket**

**Part No; PLUG2**



**110V 32Amp Plug**

**Part No; PLUG3**



**110V 32Amp Socket**

**Part No; PLUG4**



**14M Extension Lead  
110V 16 AMP 1.5MM**

**Part No; EXTL14M15**



**14M Extension Lead  
110V 32 AMP 2.5MM**

**Part No; EXTL14M32AMP**



**1.5 Kva, 240V TO 110V  
Dual Outlet Transformer**

**Part No; TRAN1**



**3.3 Kva, 240V TO 110V  
Dual Outlet Transformer**

**Part No; TRAN2**



**4 Way Splitter Box 110V**

**Part No; SB1**

**42 LIGHTING**



## 40W LED MAGNETIC WORK LIGHT

# 40W WORK LIGHT

<b>Power:</b>	40W - 4000 Lumens
<b>Bulb Type:</b>	16 x 3W Bridgelux LED
<b>LED Life:</b>	50000H
<b>Battery Type:</b>	7.4V / 13200mAh Rechargeable Li-Ion Battery
<b>Runtime:</b>	4 Hours [High Output Mode], 8 Hours [Low Output Mode]
<b>Charging Time:</b>	4 - 5 Hours
<b>Input Voltage:</b>	AC: 100 - 240V / DC: 12 - 24V
<b>Interface:</b>	USB Interface for Charging Devices
<b>Magnetic:</b>	4 PCS Strong N40 Magnetic Base
<b>Dimensions:</b>	160 x 139 x 311 mm
<b>Material:</b>	Aluminium, ABS, PC
<b>4 Modes:</b>	100% - 50% - SOS - Flashing

<b>4 Power Indicator Lights:</b>	<b>Battery Status:</b>
All Four Lights On:	100 - 75%
Red, Yellow and Green Lights On:	75 - 50%
Red and Yellow Lights On:	50 - 25%
Red Light On:	25 - 5%
Red Light Flashing:	< 5%

Supplied with Mains and Car Charger



### 40W LED RECHARGABLE AND MAGNETIC WORK LIGHT

Part Code: 260152



27W LED MAGNETIC WORK LIGHT

# 27W WORK LIGHT

**Power:** 27W - 1800 Lumens  
**Bulb Type:** 9 x 3W Epistar LED  
**LED Life:** 50000H

**Battery Type:** 7.4V / 8800mAh Li-Ion Rechargeable Battery  
**Runtime:** 3 Hours [High Output Mode], 6 Hours [Low Output Mode]  
**Charging Time:** 5 - 6 Hours  
**Input Voltage:** AC: 100 - 240V / DC: 12 - 24V  
**Interface:** USB Interface for Charging Devices  
**Magnetic:** 4 PCS Strong N40 Magnetic Base  
**Dimensions:** 130 x 110 x 210 mm  
**Material:** Aluminium, ABS, PC

**4 Modes:** 100% - 50% - SOS - Flashing

**4 Power Indicator Lights:** **Battery Status:**  
 All Four Lights On: 100 - 75%  
 Red, Yellow and Green Lights On: 75 - 50%  
 Red and Yellow Lights On: 50 - 25%  
 Red Light On: 25 - 5%  
 Red Light Flashing: < 5%

Supplied with Mains and Car Charger



www.stelrail.co.uk

## WORK LIGHT

- LED power: 27W.
- Max output 1800 lumens.
- Die-Casting Aluminium head, durable and perfect heat dissipation.
- USB interface, available for charging mobile phone when emergency.
- 4 pcs strong N40 Magnets on the bottom.
- Spot Beam angle: 60°
- LED color temperature: 6500K.
- LED life: 50000H.
- Input Voltage: AC:100-240V,DC:12-24V.
- Battery capacity: 8800 mAh.
- Charge time: 5-6 hours.
- Running time after full recharge: 5 hours and 30 minutes.
- Power indicator light: 4 lights, two green lights, one orange light, one red light.
- When the first green light goes off, about 25% power finished. When second green light goes off, 50% power finished. When orange light goes off, 75% power finished. When red light flashing every second, this means below 5% power left.

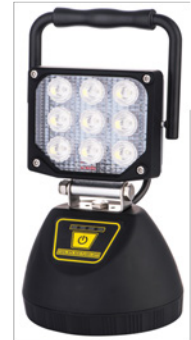

RECHARGEABLE CONSOLE LED WORK LIGHT	
Part Code	260150
Material	Aluminium, ABS, PC
Operation	4 modes: 100% - 50% - SOS - Flashing - OFF
Bulb type	9 x 3W Epistar LED
Battery type	7.4V/8800 mAh Li-Ion rechargeable battery
Product size	13x11x21cm



Specialised Tools And Equipment Ltd  
 Unit 15, 1  
 Colindale Road Business Centre  
 Colindale Road  
 Shefffield  
 S19 5WJ

T: 0114 363 0110  
 F: 0114 363 0100  
 info@stelrail.co.uk  
 www.stelrail.co.uk

27W LED RECHARGEABLE AND MAGNETIC WORK LIGHT

Part Code: 260150



44 LIGHTING & POWER



## Emergency G - Clamp

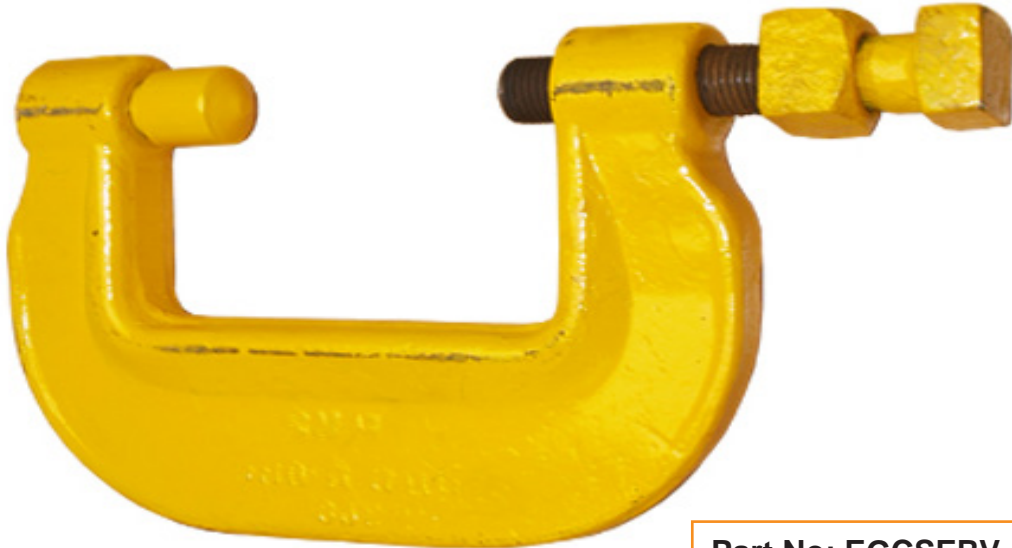

Part No; EGCSERV

Emergency Serviceable G Clamp Are Only Available When In Stock

Suitable for Common Rail Profiles;  
95RBS BH/97.1/2 BH, 109/BS110A/BS113A FB, CEN60 E1/E2

New G Clamps Also Available, Please Contact Us with Your Requirements

## Fishplates

We Supply A Wide Range Of New And  
Serviceable Fish Plates  
Please Contact Us With Your Requirements



## FASSETTA CLAMPS AND BOLTS

### Fassetta Clamp



Part No; FASSCLAMP1

Designed For Clamping Rail Joints, Broken And Defective Rails In Accordance With The Requirements Of Network Rail Specification.

For Use With Flat Bottom Profiles BR109, BS110A, BS113A Or 60EI (UIC60)

Maxim Torque; 350LB (460NM) - Do Not Overtighten  
(80LB & Underground Clamps Also Available)

Used / Serviceable Fassetta Clamps Also Available, Please Contact Us with Your Requirements

### Fassetta Bolt



Part No; FASSETTA

Fassetta Bolt Complete With Nut And Washer  
**MUST ONLY BE USED ONCE IN ACCORDANCE TO NETWORK RAIL STANDARDS**

## THERMOMETERS

### Digital Rail Thermometer



Part No; LTRT01

#### Features;

- Magnetic
- Digital Readout
- Displays Celsius or Fahrenheit
- Range -50C to +70C (-58F to +158F)
- Measures ambient and rail temperature
- 3m lead allows reading to be taken away from rail
- Large, robust, rubber rail sensor (magnetic)
- Clock function
- Back light display

### Analogue Rail Thermometer



Part No; 0039066333

#### Features;

- Magnetic mounting dial thermometer
- Range -30C to +60C
- Measures ambient and rail temperature

## TRACK TRUMETERS

### Single Track Trumeter Rail Measuring Wheel



The Definitive tool for accurate measuring of rail track. This robust, quality product was designed with input from international railroad companies and is in daily use worldwide. The heavy duty measuring wheel incorporates metal side plates keeping the wheel stable on the rail

- Large Display Mechanical Counter
- Adds and Subtracts in Reverse
- Range 0 - 99999.9M or Yards
- Range 0 - 99999' 11"
- Accuracy  $\pm 1\%$

Part No; 5061

### Dual Track Trumeter Rail Measuring Wheel



The Definitive tool for accurate measuring of rail track. This robust, quality product was designed with input from international railroad companies and is in daily use worldwide. The heavy duty measuring wheel incorporates metal side plates keeping the wheel stable on the rail

- Large Display Mechanical Counter
- Adds and Subtracts in Reverse
- Range 0 - 99999.9M or Yards
- Range 0 - 99999' 11"
- Accuracy  $\pm 1\%$

Part No; 5063

48 TRACK MEASURING

## INSULATED WHEEL BARROW

# STEL's INSULATED WHEEL BARROW



## Features;

- Insulated Polyethylene wheelbarrow is rugged and non conductive making it ideal for Network Rail Railway use or for Utilities.
- Double skin oversized heavy duty bucket is extremely strong and holds upto six builders blocks.
- Insulated non conductive and non corrosive barrow.
- Heavy Duty Double 6mm walls for durability.
- Non metallic- one piece extra strong LLDPE moulding.
- Reinforced long handles with grips (see pic 2) for manoeuvrability.
- Extra strong tipping bar (pic 3).
- 90 Litre/ 20 Gallon approx. capacity.
- One pice construction. No bolt/ rivet stress points like traditional barrows.
- 400mm 4-ply pneumatic wheel.
- 20 mm nylon rod axle for strength.
- Weight (empty) 12 kg.
- L 1540 x W 615 x H 620mm

Part No; STELBARROWPP



**LIFTING**

**LONDON UNDERGROUND SPECIFIC**  
Fitted With Insulated Wheels With Nylon Platform Protectors

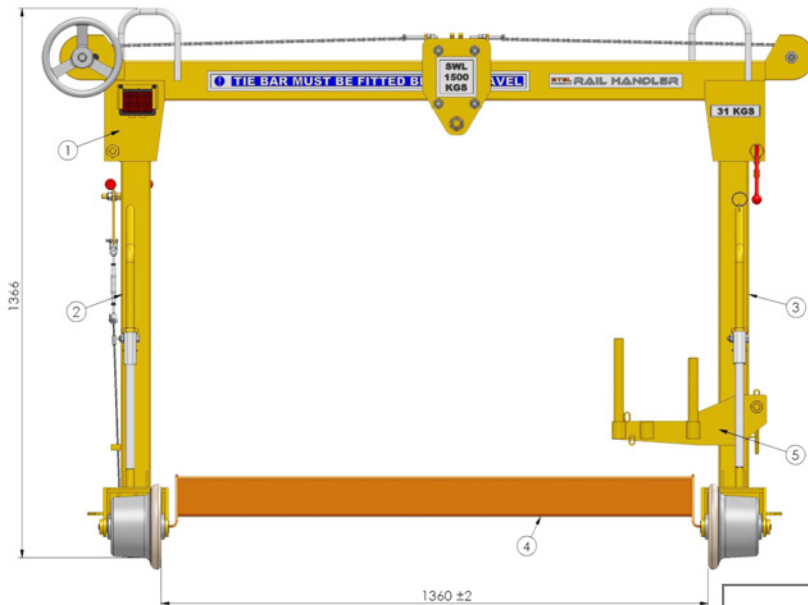

Part No ; IM1500LU  
(London Underground)

Width	1935mm
Length	1085mm
Height	1410mm
Mass	148kg (with lifting equipment)
Carriage Assembly	31kg
Bottom Beam	12kg
Braked Frame	32kg
Un-Braked Frame	30kg
Rail Storage Bracket	7kg
Yale Pul - Lift	15kg
Camlok Rail Clamp	13kg
LUL Rail Clamp	8kg
Pul - Lift to Rail Clamp Adaptor	1kg

Operation Limits Of Rail Handler	
Maximum SWL	1500kg
Maximum Track Cant	150 mm
Maximum ground cross level when transporting	150 mm
Maximum unsupported rail overhang	3m
Maximum length of rail that can be handled	100m
Maximum gradient	1:27

Operation Limits Of Lifting Equipment	
Yale Pul - Lift	1500kg
Camlok Rail Clamp	1000kg
LUL Rail Clamp	1500kg
Pul - Lift Rail Clamp Adaptor	1500kg

**Compliance:**  
Machinery Directive 98/37/EC  
A certificate of Conformity is supplied with each Rail Handler.  
RIS-1701 and BSEN13977 (Where applicable).  
LUL Certificate No: PE007/1727

The measured Hand Arm Vibration (HAV) operator's exposure is less than the 2.5ms-2 and therefore no related occupational health measures need to be undertaken. There is an uncertainty to the values stated if 50% Whole Body Vibration (WBV) is not applicable.

50 SMALL PLANT



LIFTING

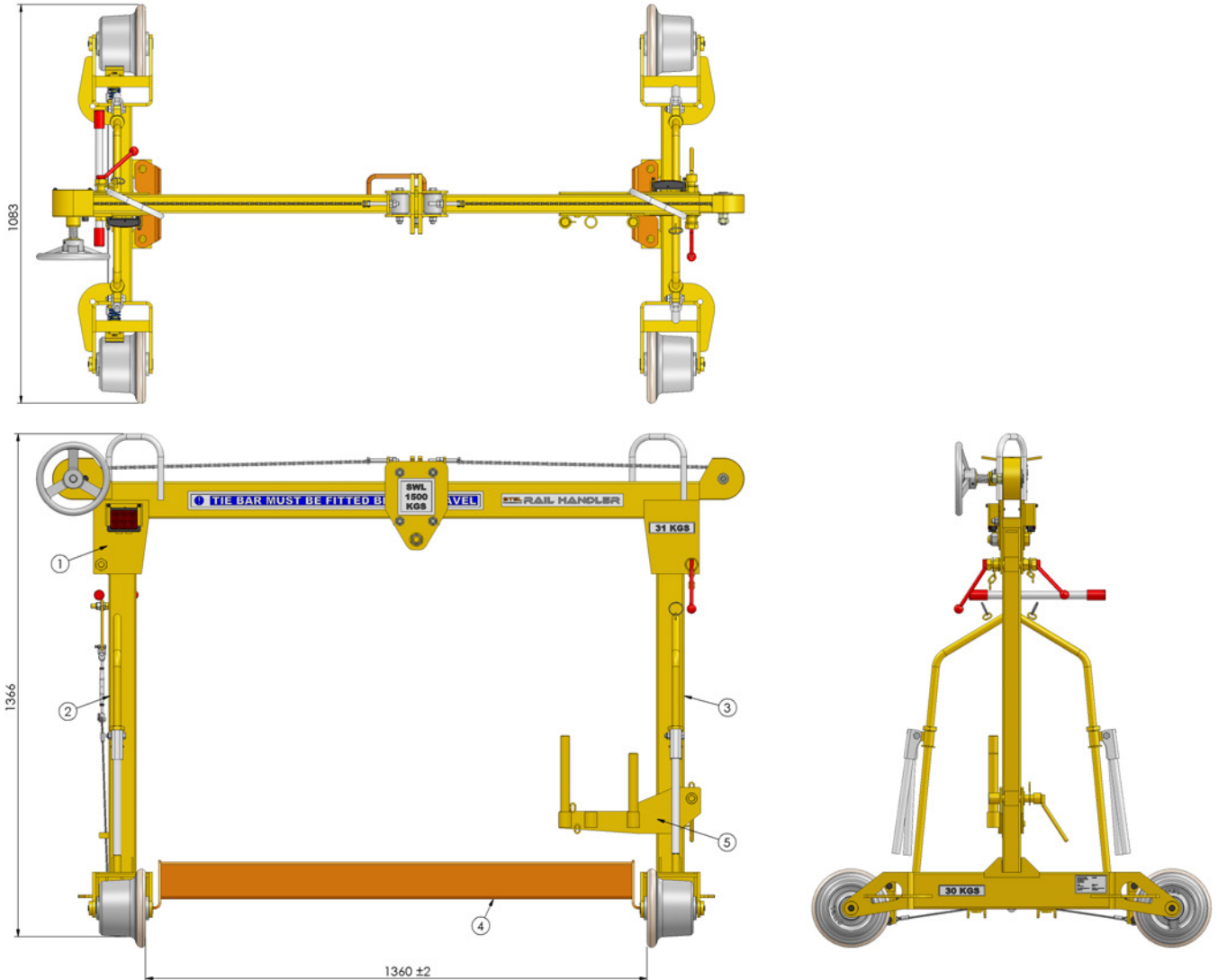

Pos;	Part No;	Description;	Qty;
1	IMTBA	Rail Handler Top Beam Assy	1
2	IMBLLU	Braked Leg Assembly (LUL)	1
3	IMUBLLU	Un-Braked Leg Assembly (LUL)	1
4	IMLBF	Bottom Beam Fabrication	1
5	IMRCB	Rail Carrier Assembly	1

LIFTING

Top Beam Assembly

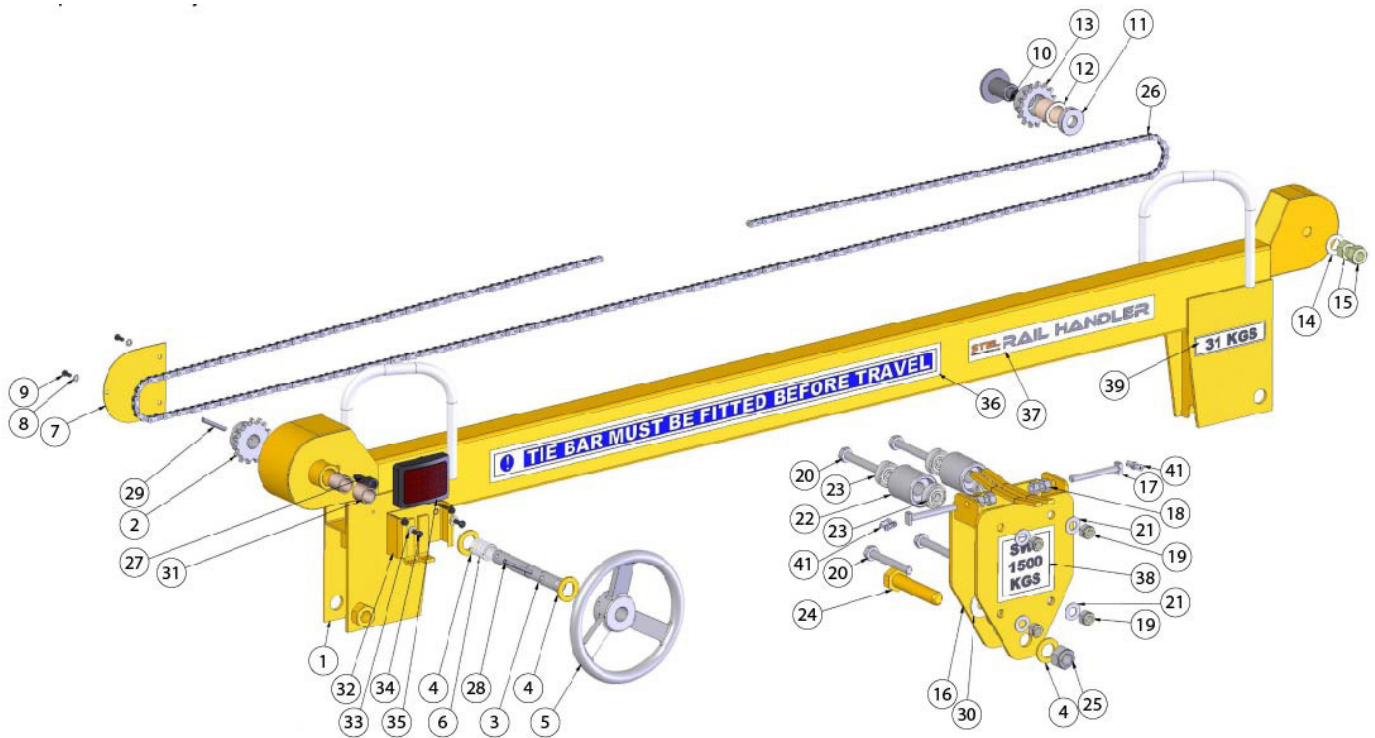

Pos;	Part No;	Description;	Qty;
1	IMTBFAB	Top Beam Fabrication	1
2	IM026	Cross Drive Sprocket	1
3	IM027	Drive Shaft	1
4	FWR-M20	M20 Flat Washer Thick	3
5	IM028	Cross Drive Hand Wheel	1
6	IM029	Hand Wheel Spring	1
7	IM030	Guard Plate	1
8	FWR-M5	M5 Flat Washer	3
9	SC512BUT	M5 x 12 Lg Button Skt Screw	3
10	IM031	Idler Shaft Assembly	1
11	IM032	Idler Shaft Spacer	1
12	IM033	Idler Sprocket Bush	1
13	IM034	Idler Sprocket	1
14	FWR-M16	M16 Flat Washer	1
15	NUT-M16	M16 Full Nut	2
16	IM035	Carriage Fabrication	1
17	IM036	Adjustment Screw	2
18	NUT-M10	M10 Full Nut	4
19	NYLOC_NUT-M12	M12 Nyloc Nut	4
20	FB1290	M12 x 90 Lg Bolt	4
21	FWR-M12	M12 Flat Washer	4

Pos;	Part No;	Description;	Qty;
22	IM037	Roller	2
23	6301_2Z	Bearings	4
24	FB20100	M20 x 100 Lg Bolt	1
25	NYLOC-M20	M20 Nyloc Nut	1
26	IM038	1/2" Pitch Chain 3448mm Long	1
27	IM039	Sprocket Stop Screw	1
28	SELPIN655	ø6 x 55 Lg Seloc Pin	1
29	SELPIN645	ø6 x 45 Lg Seloc Pin	1
30	IM040	Nylon Washer	4
31	IM042	Bush	2
32	LLBNEW	LED Light Bracket	2
33	FWR-M6	M6 Flat Washer	4
34	SC616BUT	M6 x 16 Button Head Screw	4
35	REDLED	LED Warning Light	2
36	IMLABEL01	Rail Handler Decal 800x50	2
37	IMLABEL02	Rail Handler Decal 330x35	2
38	IMLABEL03	Rail Handler Decal 100x100 SWL 1500KGs	2
39	IMLABEL04	Rail Handler Decal 125x30 31KGs	1
40	IMLABEL09	Rail Handler Serial Decal 85x50	1
41	SPLITL1_2	1/2" Pitch Split Link	2
42	IMLABEL12	Rail Handler Warning Decal 85x45	1

## LIFTING

### Braked Leg Assembly

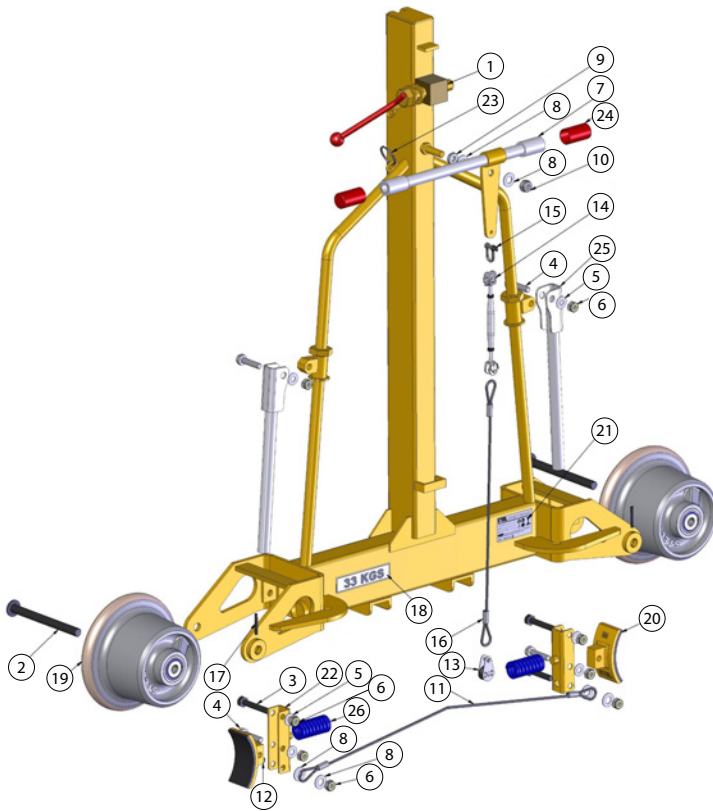

Pos;	Part No;	Description;	Qty;
1	IMBLFAB	Braked Leg Fab'n	1
2	IM001	Axel Fab'n	2
3	FB1065	M10 x 65 Lg Bolt	2
4	FB1045	M10 x 45 Lg Bolt	4
5	FWR-M10	M10 Flat Washer	6
6	NYLOC_NUT-M10	M10 Nyloc Nut	8
7	IMBHFAB	Brake Actuator Arm Assembly	1
8	FWR-M12	M12 Flat Washer	6
9	NUT-M12LOCK	M12 Lock Nut	1
10	LOCNUT-M12	M12 Nyloc Nut	1
11	IMCAB01	Horizontal Brake Cable	1
12	FB1055	M10 x 55 Lg Bolt	2
13	IM053	Cable Pulley	1
14	LTB	Turnbuckle Assembly	1
15	LTUB	D Shackle Type B130	1
16	IMCAB02	Vertical Brake Cable	1
17	SELPIN538	ø5 x 38 Lg Seloc Pin	2
18	IMLABEL05	Rail Handler Decal 125x30 33KGs	1
19	HRHW	Hybrid Ironman Wheel	2
20	IMBSAN	Brake Shoe Assembly Rail Handler	2
21	IMLABEL09	Rail Handler Serial Decal 80x45	1
22	IMBAFAB2	Brake Arm w/a LU	2
23	KR7052F	Securing Ring	1
24	CD388	Plastic End Cap	2
25	IMLH	Lifting Handle Fab'n	2
26	IMBSPR3	Ironman Brake Spring 64mm	2

### Traverse Leg Assembly



Pos;	Part No;	Description;	Qty;
1	IMBLFAB	Un Braked Leg Fab'n	1
2	IM001	Axel Fab'n	2
3	SELPIN538	5 x 38 Lg Seloc Pin	2
4	IMLABEL06	Rail Handler Decal	1
5	HRHW	Hybrid Ironman Wheel	2
6	IMLABEL09	Rail Handler Serial Decal	1
7	KR7052F	Securing Ring	1
8	IMLH	Lifting Handle Fab'n	2
9	FB1045	M10 x 45 Lg Bolt	2
10	FWR-M10	M10 Flat Washer	2
11	NYLOC_NUT-M10	M10 Nyloc Nut	2

LIFTING

NETWORK RAIL SPECIFIC  
Fitted With Aluminium Wheels

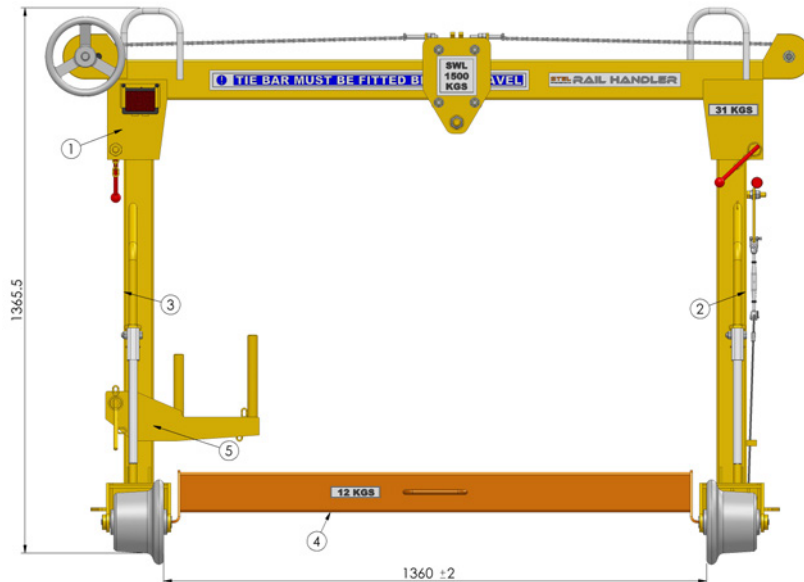

Part No ; IM1500NWR  
(Network Rail)

Width	1935mm
Length	1085mm
Height	1410mm
Mass	148kg (with lifting equipment)
Carriage Assembly	31kg
Bottom Beam	12kg
Braked Frame	32kg
Un-Braked Frame	30kg
Rail Storage Bracket	7kg
Yale Pul - Lift	15kg
Camlok Rail Clamp	13kg
LUL Rail Clamp	8kg
Pul - Lift to Rail Clamp Adaptor	1kg

Operation Limits Of Rail Handler	
Maximum SWL	1500kg
Maximum Track Cant	150 mm
Maximum ground cross level when transporting	150 mm
Maximum unsupported rail overhang	3m
Maximum length of rail that can be handled	100m
Maximum gradient	1:27

Operation Limits Of Lifting Equipment	
Yale Pul - Lift	1500kg
Camlok Rail Clamp	1000kg
LUL Rail Clamp	1500kg
Pul - Lift Rail Clamp Adaptor	1500kg

Compliance:  
Machinery Directive 98/37/EC  
A certificate of Conformity is supplied with each Rail Handler.  
RIS-1701 and BSEN13977 (Where applicable).  
LUL Certificate No: PE007/1727

The measured Hand Arm Vibration (HAV) operator's exposure is less than the 2.5ms-2 and therefore no related occupational health measures need to be undertaken. There is an uncertainty to the values stated if 50% Whole Body Vibration (WBV) is not applicable.

54 SMALL PLANT



LIFTING

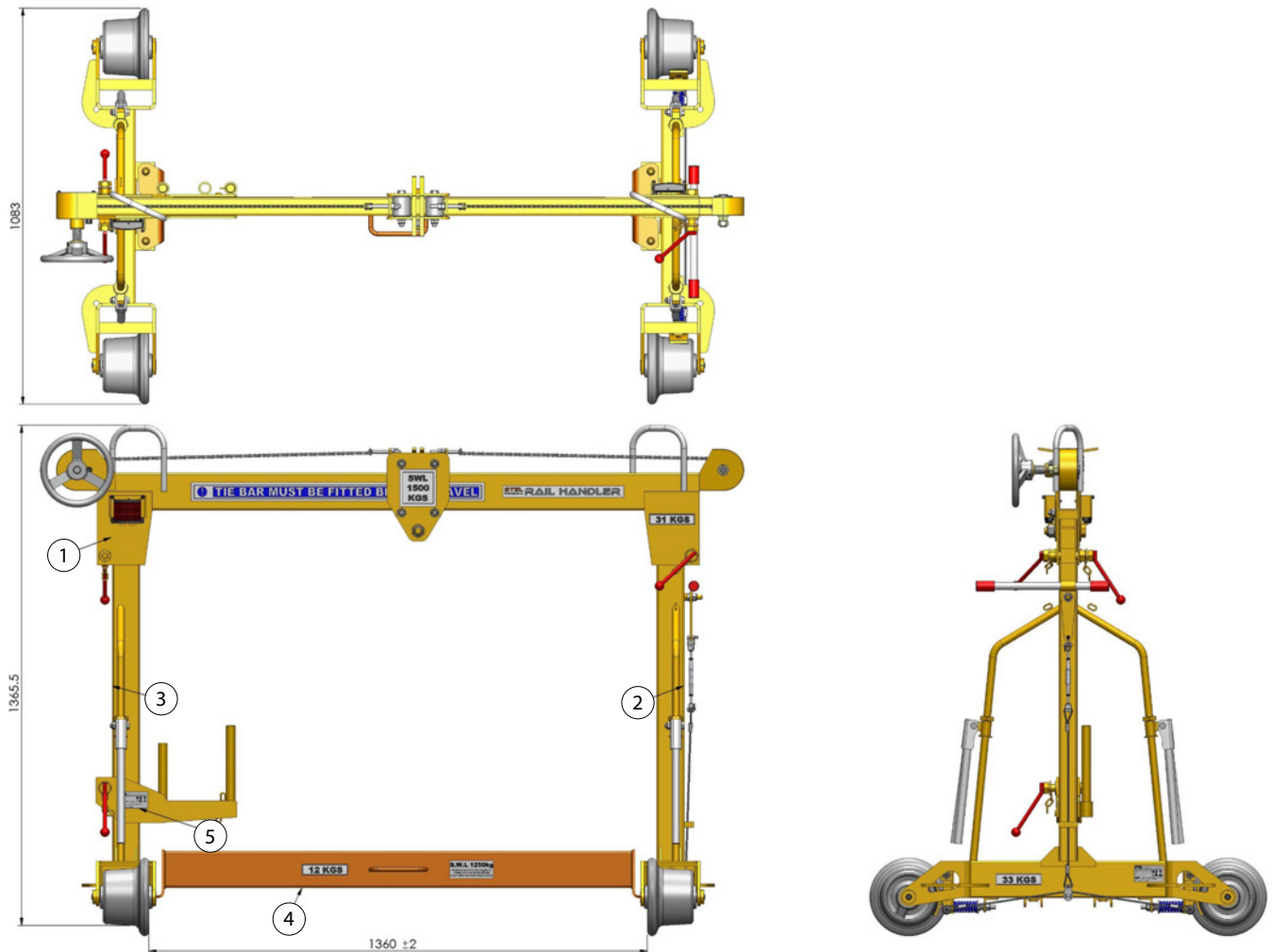

Pos;	Part No;	Description;	Qty;
1	IMTBA	Rail Handler Top Beam Assy	1
2	IMBLLU	Braked Leg Assembly (NWR)	1
3	IMUBLLU	Un-Braked Leg Assembly (NWR)	1
4	IMLBF	Bottom Beam Fabrication	1
5	IMRCB	Rail Carrier Assembly	1



LIFTING

Top Beam Assembly

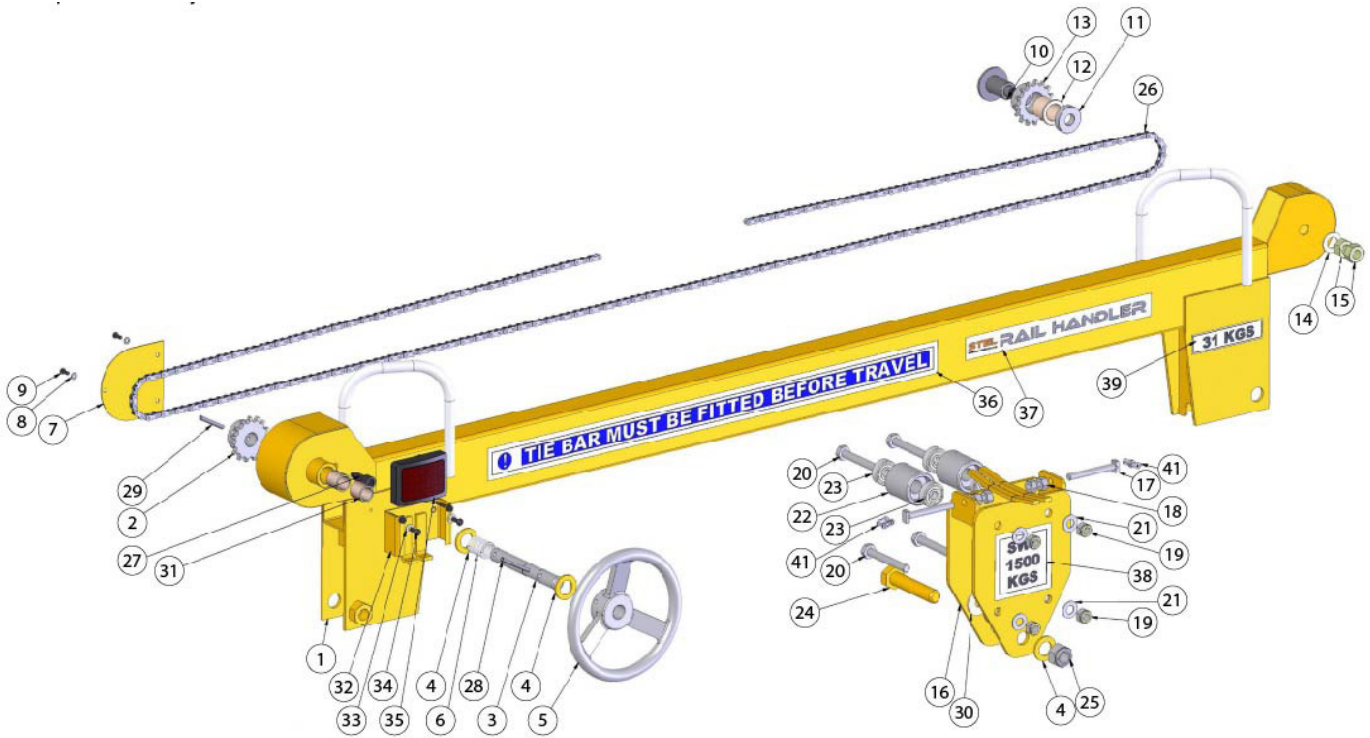

Pos;	Part No;	Description;	Qty;
1	IMTBFAB	Top Beam Fabrication	1
2	IM026	Cross Drive Sprocket	1
3	IM027	Drive Shaft	1
4	FWR-M20	M20 Flat Washer Thick	3
5	IM028	Cross Drive Hand Wheel	1
6	IM029	Hand Wheel Spring	1
7	IM030	Guard Plate	1
8	FWR-M5	M5 Flat Washer	3
9	SC512BUT	M5 x 12 Lg Button Skt Screw	3
10	IM031	Idler Shaft Assembly	1
11	IM032	Idler Shaft Spacer	1
12	IM033	Idler Sprocket Bush	1
13	IM034	Idler Sprocket	1
14	FWR-M16	M16 Flat Washer	1
15	NUT-M16	M16 Full Nut	2
16	IM035	Carriage Fabrication	1
17	IM036	Adjustment Screw	2
18	NUT-M10	M10 Full Nut	4
19	NYLOC_NUT-M12	M12 Nyloc Nut	4
20	FB1290	M12 x 90 Lg Bolt	4
21	FWR-M12	M12 Flat Washer	4

Pos;	Part No;	Description;	Qty;
22	IM037	Roller	2
23	6301_2Z	Bearings	4
24	FB20100	M20 x 100 Lg Bolt	1
25	NYLOC-M20	M20 Nyloc Nut	1
26	IM038	1/2" Pitch Chain 3448mm Long	1
27	IM039	Sprocket Stop Screw	1
28	SELPIN655	ø6 x 55 Lg Seloc Pin	1
29	SELPIN645	ø6 x 45 Lg Seloc Pin	1
30	IM040	Nylon Washer	4
31	IM042	Bush	2
32	LLBNEW	LED Light Bracket	2
33	FWR-M6	M6 Flat Washer	4
34	SC616BUT	M6 x 16 Button Head Screw	4
35	REDLED	LED Warning Light	2
36	IMLABEL01	Rail Handler Decal 800x50	2
37	IMLABEL02	Rail Handler Decal 330x35	2
38	IMLABEL03	Rail Handler Decal 100x100 SWL 1500KGs	2
39	IMLABEL04	Rail Handler Decal 125x30 31KGs	1
40	IMLABEL09	Rail Handler Serial Decal 85x50	1
41	SPLITL1_2	1/2" Pitch Split Link	2
42	IMLABEL12	Rail Handler Warning Decal 85x45	1

56 SMALL PLANT

## LIFTING

### Braked Leg Assembly

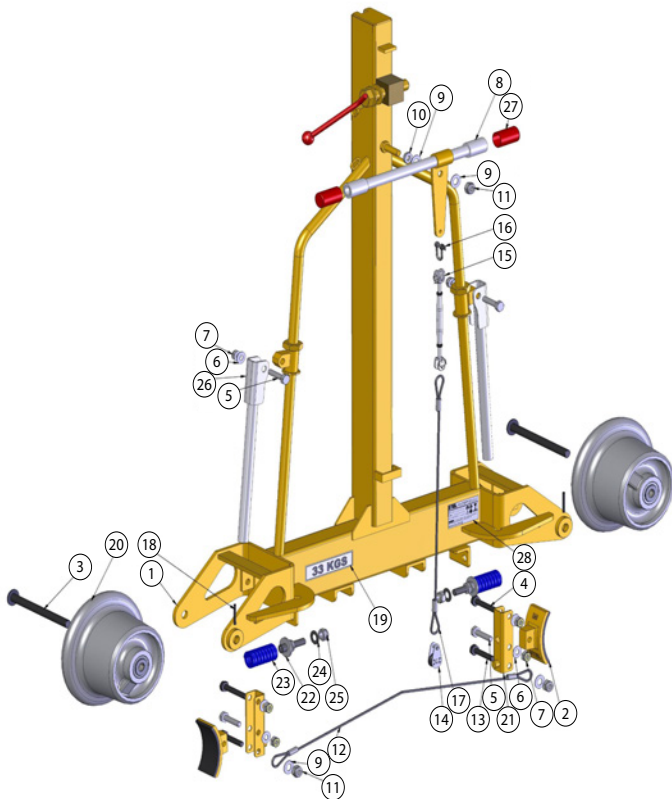

Pos;	Part No;	Description;	Qty;
1	IMBLFAB	Braked Leg Fab'n	1
2	IMBSAN	Brake Shoe Assembly Rail Handler	2
3	IM001	Axle Fab'n	2
4	FB1065	M10 x 65 Lg Bolt	2
5	FB1045	M10 x 45 Lg Bolt	4
6	FWR-M10	M10 Flat Washer	6
7	NYLOC_NUT-M10	M10 Nyloc Nut	6
8	IMBHFAB	Brake Actuator Arm Assembly	1
9	FWR-M12	M12 Flat Washer	4
10	NUT-M12LOCK	M12 Lock Nut	1
11	LOCNUT-M12	M12 Nyloc Nut	3
12	IMCAB01	Horizontal Brake Cable	1
13	FB1055	M10 x 55 Lg Bolt	2
14	IM053	Cable Pulley	1
15	LTB	Turnbuckle Assembly	1
16	LTUB	D Shackle Type B130	1
17	IMCAB02	Vertical Brake Cable	1
18	SELPIN538	ø5 x 38 Lg Seloc Pin	2
19	IMLABEL05	Rail Handler Decal 125x30 33KGs	1
20	IM003	Wheel Assembly	2
21	IM057	Brake Arm w/a NWR	2
22	LBSA	Brake Spring Adjuster	2
23	IMBSPR3	Ironman Brake Spring 64mm	2
24	FWR-M12-BZP	M12 Flat Washer	2
25	NYLOC_NUT-M12	M12 Nyloc Nut	2
26	IMLH	Lifting Handle Fab'n	2
27	CD388	Plastic End Cap	2
28	IMLABEL09	Rail Handler Serial Decal 80x45	1

### Traverse Leg Assembly



Pos;	Part No;	Description;	Qty;
1	IMTLFAB	Un-Braked Leg Fab'n	1
2	IM001	Axle Fab'n	2
3	IMLH	Lifting Handle Fab'n	2
4	NYLOC_NUT-M10	M10 Nyloc Nut	2
5	FWR-M10	M10 Flat Washer	2
6	FB1045	M10 x 45 Lg Bolt	2
7	IM003	Wheel Assembly	2
8	SELPIN538	ø5 x 38 Lg Seloc Pin	2
9	IMLABEL06	Rail Handler Decal 125x30 27KGs	1

**B - TYPE TROLLEY**

**LONDON UNDERGROUND SPECIFIC**  
Fitted With Insulated Aluminium Wheels And Aluminum Deck



**Compliance;**  
In accordance with the following directive(s):-

Machinery Directive 2006/41/EC.  
Directive 93/68/EEC CE Marking.

BS EN 13977:2011: Railway application - Track  
- Safety requirements for portable machines  
and trolleys for construction and maintenance.

RIS 1701 PLT: Rail Industry Standard for Portable  
and Transportable Plant Used for Infrastructure Work.

Cop0018: Code of Practice for Rail Mounted  
Manually Propelled Equipment.

LUL Certificate No: PR007/1729.

**Part No ; BT1000LU**  
**(London Underground Rail)**

Width	1876mm
Length	1689.5mm
Height	335mm (without brake and push handles fitted)
Mass	135kg

**Operation Limits**

**Maximum SWL outside UK - 2000kg**  
**Maximum SWL in UK - 1000kg**

LIFTING

B - Type Split Trolley Assembly

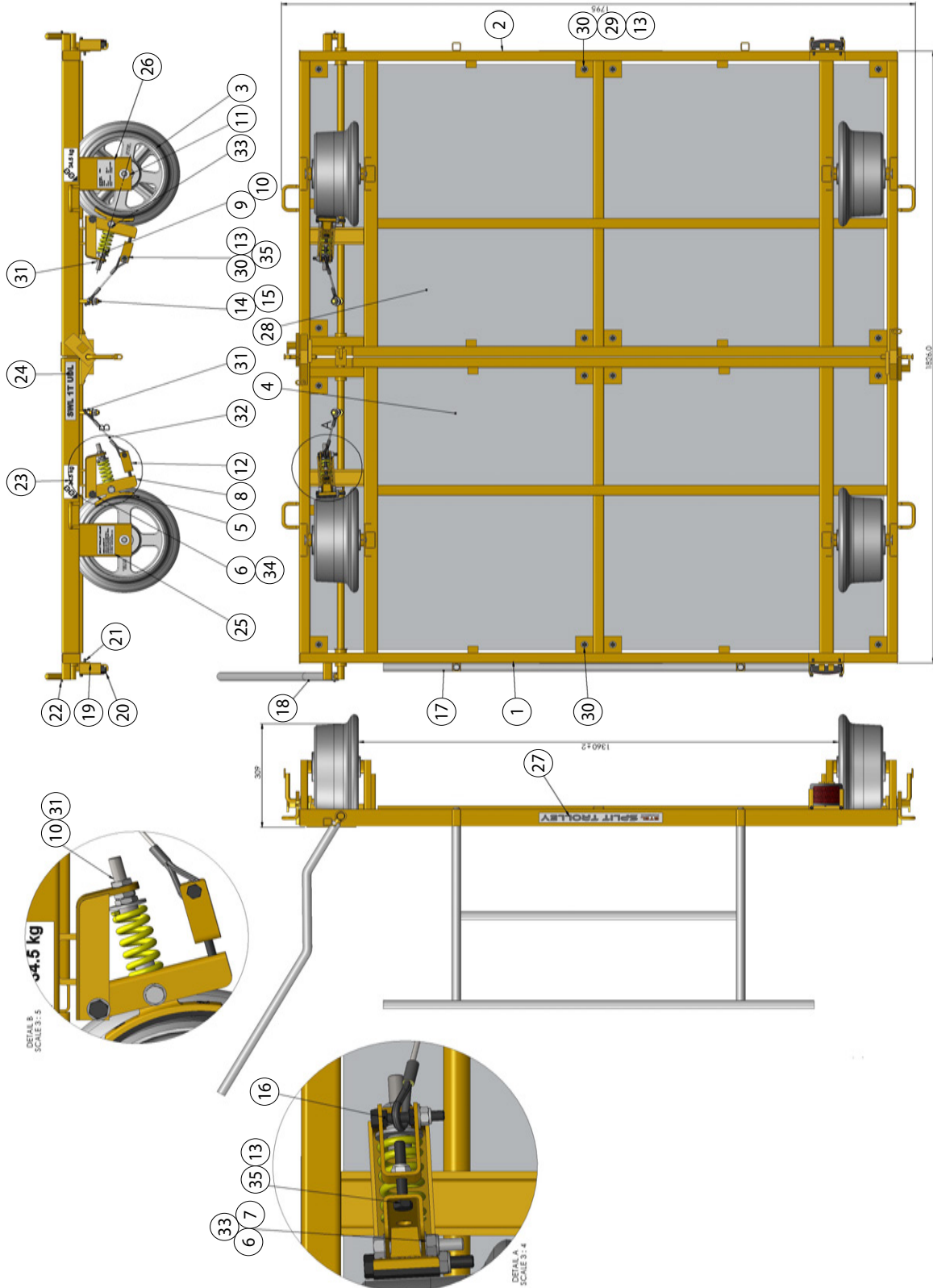



**B - TYPE TROLLEY**
**B - Type Split Trolley Parts List**

Pos;	Part No;	Description;	Qty;
1	800010	Chassis, Female	1
2	800011	Chassis, Male	1
3	WHEEL2	Insulated Wheel	4
4 & 28	BTTAP	Aluminium Deck	2
5	BTBSSTEL	Brake Shoe	2
6	FWR-M10	M10 Flat Washer	8
7	NYLOC_NUT-M10	M10 Nylock Nut	4
8	800008	Pivot Member	2
9	LBSY	Brake Spring	2
10	LBSA	Brake Spring Adjuster	2
11	800005	Wheel Axle	4
12	800006	Adjuster	2
13	NYLOC_NUT-M8	M8 Nylock Nut	20
14	NYLOC_NUT-M12	M12 Nylock Nut	2
15	FWR-M12	M12 Flat Washer	2
16	NUT-M8LOCK	M8 Lock Nut	2
17	BTPB	Push Bar	4
18	BTBBDC	Brake Bar	1
19	LLBNEW	Light Bracket	2
20	REDLED	Led Light	2
21	SC616BUT	M6 X 16 Button Head Screw	4
22	SELPIN525	5Mm Ø X 25Mm Selloc Pin	2
23	STLABEL05	B Type Label, Split Trolley Decal, Lifting Point	4
24	STLABEL03	B Type Label, Split Trolley Decal, 175Mm X 30Mm	2
25	STLABEL02	B Type Label, Split Trolley Decal, 85Mm X 50	1
26	STLABEL04	B Type Label, Split Trolley Decal, 85Mm X 50Mm	2
27	STLABEL01	B Type Label, Split Trolley Decal, 350Mm X 30Mm	2
29	M8 X 30MM C/S	M8 X 25Mm Counter Sunk Screw, Aluminium Top Only	12
30	FWR-M8	M8 Flat Washer	18
31	NUT-M12LOCK	M12 Lock Nut	4
32	BTBCSTEL	Brake Cable	2
33	FB1060	M10 X 60Mm Bolt	2
34	FB1075	M10 X 75Mm Bolt	2
35	800034	M8 X 50Mm Bolt	4
36	SELPIN540	5Mm Ø X 40Mm Selloc Pin	4
	STEL518	Pin & Chain Connector	
	63022RS	Wheel Bearing	
	WHEEL2BUSH	Wheel Insulating Bush	



## B - TYPE TROLLEY

### NETWORK RAIL SPECIFIC

Fitted With Aluminium Wheels And Wooden Deck



**Compliance;**  
In accordance with the following directive(s):-

**Machinery Directive 2006/41/EC.**  
**Directive 93/68/EEC CE Marking.**

**BS EN 13977:2011: Railway application - Track**  
**- Safety requirements for portable machines**  
**and trolleys for construction and maintenance.**

**RIS 1701 PLT: Rail Industry Standard for Portable**  
**and Transportable Plant Used for Infrastructure Work.**

**Cop0018: Code of Practice for Rail Mounted**  
**Manually Propelled Equipment.**

**NWR Certificate No: PA05/05770.**

**Part No ; BT1000NWR**  
**(Network Rail)**

<b>Width</b>	<b>1876mm</b>
<b>Length</b>	<b>1689.5mm</b>
<b>Height</b>	<b>335mm (without</b> <b>brake and push</b> <b>handles fitted</b>
<b>Mass</b>	<b>135kg</b>

#### Operation Limits

**Maximum SWL outside UK - 2000kg**  
**Maximum SWL in UK - 1000kg**

**B - TYPE TROLLEY**

**B - Type Split Trolley Assembly**

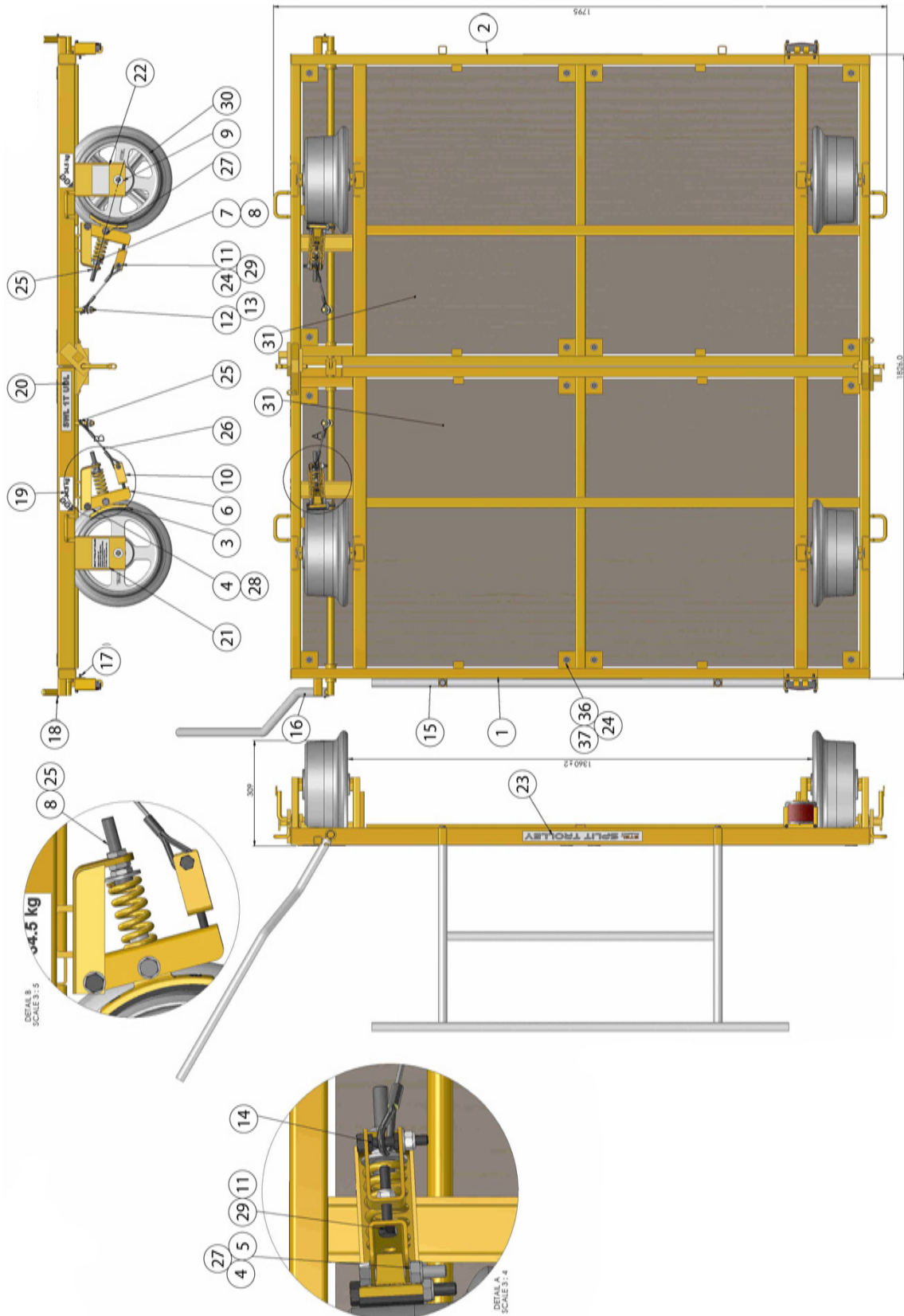

**B - TYPE TROLLEY**
**B - Type Split Trolley Parts List**

Pos;	Part Number;	Description;	Qty;
1	800010	Chassis, Female	1
2	800011	Chassis, Male	1
3	BTBSSTEL	Brake Shoe	2
4	FWR-M10	M10 Flat Washer	8
5	NYLOC_NUT-M10	M10 Nyloc Nut	4
6	800008	Pivot Member	2
7	LBSY	Brake Spring	2
8	LBSA	Brake Spring Adjuster	2
9	800005	Wheel Axle	4
10	800006	Adjuster	2
11	NYLOC_NUT-M8	M8 Nyloc Nut	20
12	NYLOC_NUT-M12	M12 Nylock Nut	2
13	FWR-M12	M12 Flat Washer	2
14	NUT-M8 LOCK	M8 Lock Nut	4
15	BTPB	Push Bar	1
16	BTBBDC	Brake Bar	1
17	SC616BUT	M6 X 16 Button Head Screw	4
18	SELPIN525	5Mm Ø X 25Mm Selloc Pin	2
19	STLABEL05	B Type Label, Split Trolley Decal, Lifting Point	4
20	STLABEL03	B Type Label, Split Trolley Decal, 175Mm X 30Mm	2
21	STLABEL02	B Type Label, Split Trolley Decal, 85Mm X 50	1
22	STLABEL04	B Type Label, Split Trolley Decal, 85Mm X 50Mm	2
23	STLABEL01	B Type Label, Split Trolley Decal, 350Mm X 30Mm	2
24	FWR-M8	M8 Flat Washer	18
25	NUT-M12LOCK	M12 Lock Nut	4
26	BTBCSTEL	Brake Cable	2
27	FB1060	M10 X 60Mm Bolt	2
28	FB1075	M10 X 75Mm Bolt	2
29	800034	M8 X 50Mm Bolt	4
30	WHEEL1	Un-Insulated Wheel (Nwr)	4
31	BTTWP	Wooden Top (Nwr)	1
32	SELPIN540	5Mm Ø X 40Mm Selloc Pin	4
34	LLBNEW	Light Bracket	2
35	REDLED	Led Light	2
37	F21B	Big Head Fasteners	16

**LINK TROLLEY**

**LONDON UNDERGROUND SPECIFIC**  
**Fitted With Insulated Aluminium Wheels And Aluminum Deck**



**Compliance;**  
 In accordance with the following directive(s):-

**Machinery Directive 2006/41/EC.**  
 Directive 93/68/EEC CE Marking.

**BS EN 13977:2011: Railway application - Track - Safety requirements for portable machines and trolleys for construction and maintenance.**

**RIS 1701 PLT: Rail Industry Standard for Portable and Transportable Plant Used for Infrastructure Work.**

**Cop0018: Code of Practice for Rail Mounted Manually Propelled Equipment.**

**LUL Certificate No: PR007/1728**

**Part No ; LT1000LU**  
**(London Underground)**

Width	1675mm
Length	750mm
Height	218mm (without brake and push handles fitted)
Mass	48kg

**Operation Limits**  
**Maximum SWL outside UK - 1250kg**  
**Maximum SWL in UK - 1000kg**  
**Maximum total SWL for two linked trolleys - 2000kg**  
**All loads must be uniformly distributed and positioned about the trolley centre line**

**64 SMALL PLANT**



**LINK TROLLEY**

**Link Trolley Assembly**

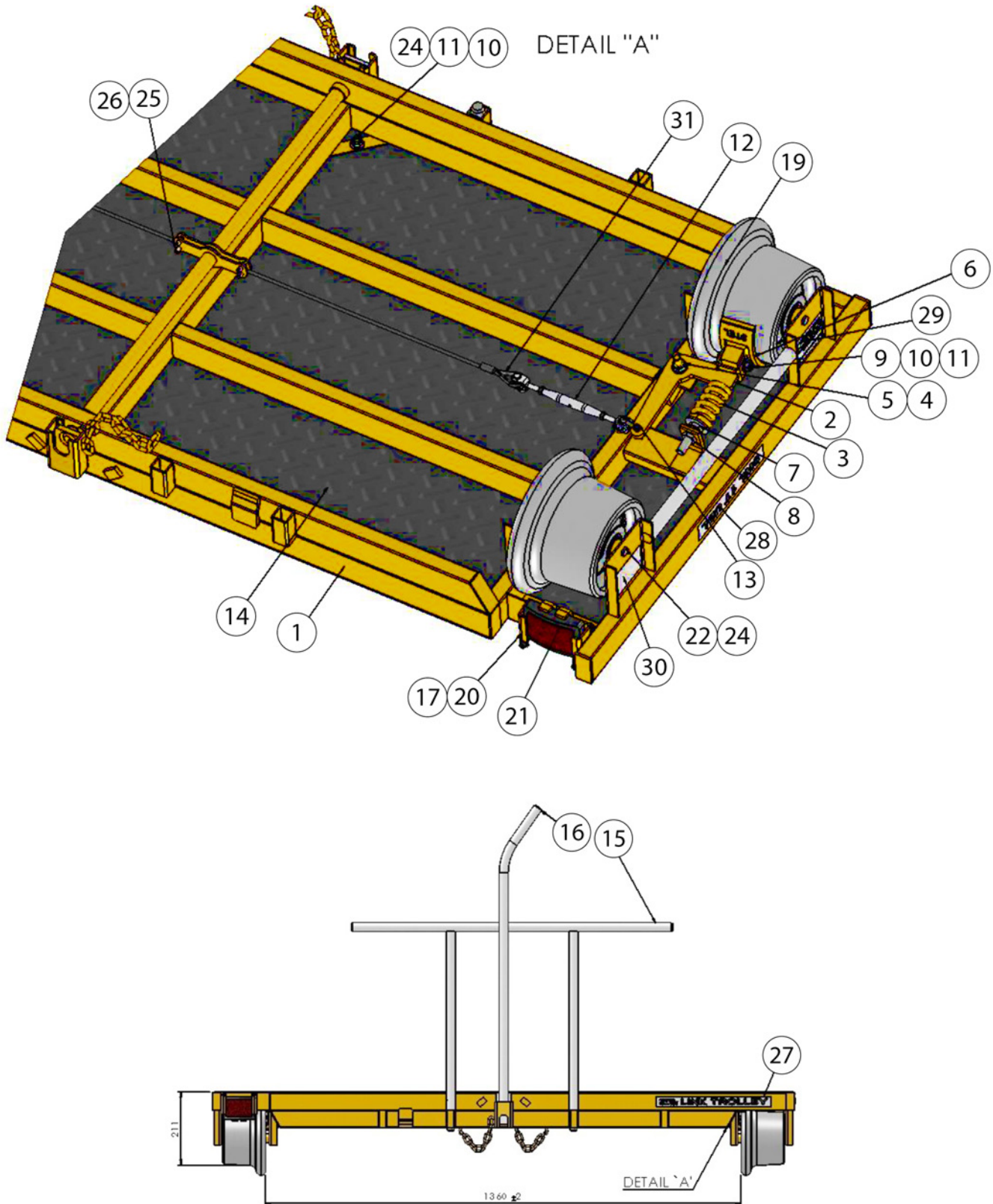



## LINK TROLLEY

### Link Trolley Parts List

Pos;	Part Number;	Description;	Qty;
1	LINK-CHASMOD	Link Trolley Chassis; Modified	1
2	LINK-BBCL	Brake Actuator	2
3	LBSY	Brake Spring Yellow	2
4	FWR-M10	M10 Flat Washer	2
5	NYLOC_NUT-M10	M10 Nyloc Nut	2
6	LBSSTELIRON	Brake Shoe Link Trolley	2
7	LBSA	Brake Spring Adjuster	2
8	NUT-M12LOCK	M12 Lock Nut	2
9	FB845	M8 X 45 Lg Bolt	2
10	FWR-M8	M8 Flt Washer	8
11	NYLOC_NUT-M8	M8 Nyloc Nut	8
12	LTB	Turn Buckle Assembly	1
13	LTUB	D Shackle Type B130	2
14	LTTAS	Aluminium 5 Bar Top	1
15	BTBP	Trolley Push Bar	1
16	LBHLU	Brake Bar	6
17	SC620CSK	M6 X 20Lg C.sunk Screw	1
19	WHEEL3	Link Trolley, Insulated Wheel, Stel	4
20	LLBNEW	Red Light Bracket	2
21	REDLED	Led Warning Light	2
22	800028	Link Trolley Axle	4
23	SELPIN1_8X1	Seloc Pin 1/8X1" Lg	4
24	SC820CSK	M8 X 20 Lg C.sunk Screw	6
25	CP620	6 X 20 Lg Clevis Pin	4
26	COT120	1 X 20 Lg Cotter Pin	4
27	LTLABEL01	Link Trolley Decal 330 X 35	2
28	STLABEL03	Split Trolley Decal 175X30	2
29	LTLABEL02	Link Trolley Decal 85 X 50	1
30	LTLABEL04	Link Trolley Serial Decal 85 X 50	1
31	LTBC	Link Trolley Brake Cable	1
32	TAPEREFLECT	Reflective White Tape 55Mm X 100Mm	4

## LINK TROLLEY

### NETWORK RAIL SPECIFIC

Fitted With Aluminium Wheels And Wooden Deck



#### Compliance;

In accordance with the following directive(s):-

Machinery Directive 2006/41/EC.  
Directive 93/68/EEC CE Marking.

BS EN 13977:2011: Railway application - Track  
- Safety requirements for portable machines  
and trolleys for construction and maintenance.

RIS 1701 PLT: Rail Industry Standard for Portable  
and Transportable Plant Used for Infrastructure Work.

Cop0018: Code of Practice for Rail Mounted  
Manually Propelled Equipment.

Network Rail Certificate No: PA05/05769

Part No ; LT1000NWR  
(Network Rail)

Width	1675mm
Length	750mm
Height	218mm (without brake and push handles fitted)
Mass	52kg

**Operation Limits**  
Maximum SWL outside UK - 1250kg  
Maximum SWL in UK - 1000kg  
Maximum total SWL for two linked trolleys -  
2000kg  
All loads must be uniformly distributed and  
positioned about the trolley centre line

LINK TROLLEY

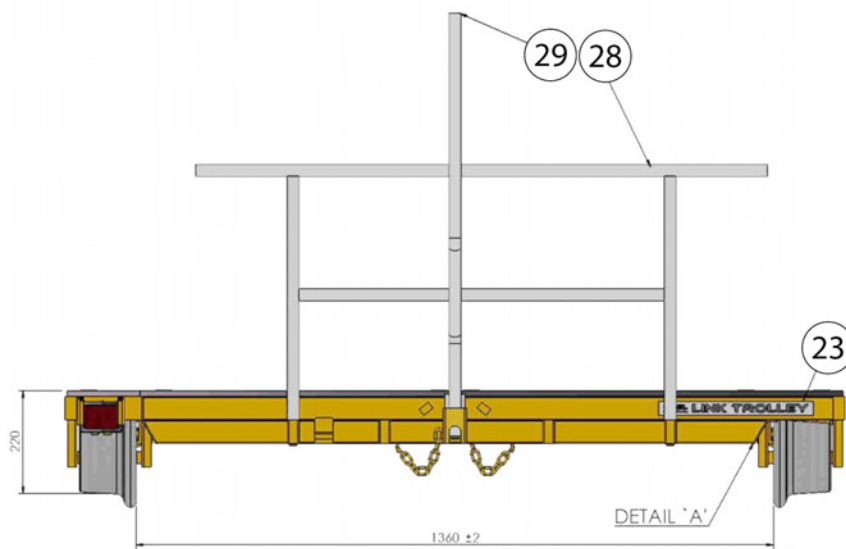
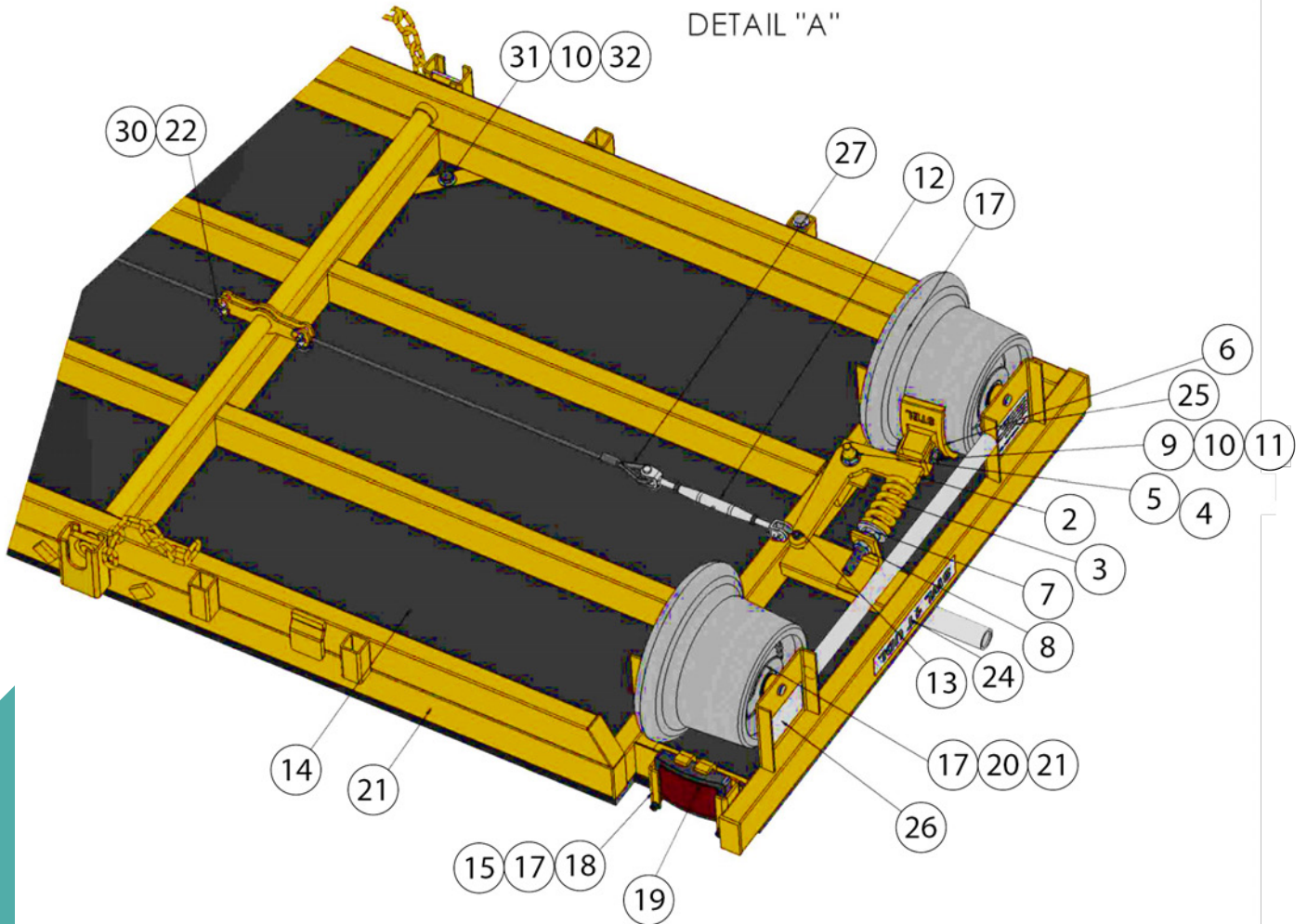

68 SMALL PLANT

## LINK TROLLEY

### Link Trolley Parts List

Pos;	Part No;	Description;	Qty;
1	LINK-CHAS	Link Trolley Chassis	1
2	LINK-BBCL	Brake Actuator	2
3	LBSY	Brake Spring Yellow	2
4	FWR-M10	M10 Flat Washer	2
5	NYLOC_NUT-M10	M10 Nyloc Nut	2
6	LBSSTELIRON	Brake Shoe Link Trolley	2
7	LBSA	Brake Spring Adjuster	2
8	NUT-M12LOCK	M12 Lock Nut	2
9	FB845	M8 X 45 Lg Bolt	2
10	FWR-M8	M8 Flat Washer	12
11	NYLOC_NUT-M8	M8 Nyloc Nut	2
12	LTB	Turnbuckle Assembly	1
13	LTUB	D Shackle Type B130	2
14	LTTWS	Plywood Top	1
15	SC620CSK	M6x20lg C.sunk Screw	4
17	WHEEL4	Link Trolley Wheel (Un-Ins)	4
18	LLBNEW	Led Light Bracket	2
19	REDLED	Led Warning Light	2
20	800028	Link Trolley Axle	4
21	SELPIN1_8x1	Seloc Pin 1/8X1" Lg	4
22	CP620	Ø6x20lg Clevis Pin	4
23	LTLABEL01	Link Trolley Decal 330X35	2
24	STLABEL03	Split Trolley Decal 175X30	2
25	LTLABEL02	Link Trolley Decal 85X50	1
26	LTLABEL04	Link Trolley Serial Decal 85X50	1
27	LTBC	Link Trolley Brake Cable	1
28	BTPB	Push Bar	1
29	LBHLU	Brake Bar (Lu)	1
30	BW-061806	G Clip	4
31	FB812	M8x12lg Bolt Bzp	10
32	F21B	M8 Bighead Fastener	10
	TAPEREFLECT	Reflective White Tape 55Mm X 100Mm	4

**TROLLEY RAMPS**

**Trolley Ramps  
Fitted With Aluminium Tread Plate**



The STEL Trolley Ramps are designed to be used to load and unload the “B” Type Trolley with heavy cargo unsuitable for lifting, or small vehicles with wheels/ tracks.

Width	355mm
Length	2000mm
Height (unfolded legs)	545mm
Height (folded legs)	150mm
Mass	35kg

Operation Limits	
Maximum SWL	1000kg (per ramp)
All loads must be uniformly distributed and positioned about the ramp centre line.	

Part No; RAMP

**Compliance:**

- In accordance with the following Directive(s):-
- Machinery Directive 2006/41/EC
- Directive 93/68/EEC CE Marking
- RIS 1701 PLT Rail Industry Standard for Portable and Transportable Plant Used for Infrastructure Work.
- Network Rail Certificate of Acceptance - PA05/05889

70 SMALL PLANT



**SKATE BASKET**

**NETWORK RAIL AND LONDON UNDERGROUND SPECIFIC**  
Fitted With Nylon Wheels



- Minimum Space Required in Vehicle
- Support Arm Works as Stabiliser during Loading and Unloading
- Reduce potential injury and fatigue to operator
- Safe and efficient method of transporting tools and smaller plant equipment to worksite
- Doesn't have any influence on axel counters, even when they are not correctly adjusted (set over height)

Network Rail Certificate Of Acceptance; PA05/05918  
Network Rail Cat no; 094/021170  
London Underground Certificate Of Acceptance;  
PE/007/1733

Part No; SBC

Width	360 mm	Reference	Title
Length	870 mm	BS EN 13977:2011	Railway application - Track - Safety requirements for portable machines and Skate Baskets for construction and maintenance.
Height	190mm (without push handles fitted)		
Height	820mm (with push handles fitted)	RIS 1701 PLT	Rail Industry Standard for Portable and Transportable Plant Used for Infrastructure Work.
Weight	13.6kg (without push handles fitted)		
Weight	17.8kg (with push handles fitted)		
Safe Working Load	(NWR Spec) 250kg		
Safe Working Load	(LU Spec) 75kg		

**SKATE BASKET**

**LONDON UNDERGROUND SPECIFIC**

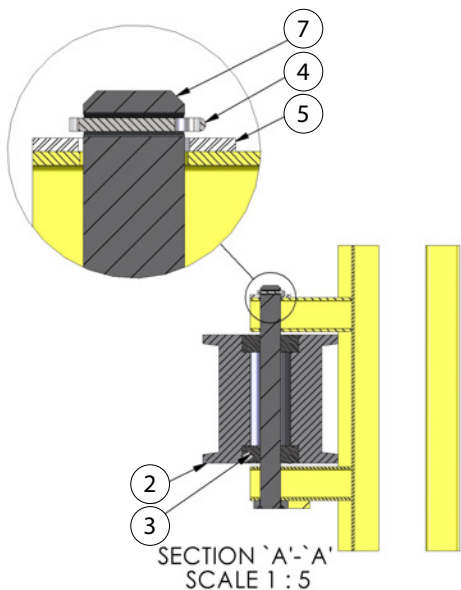
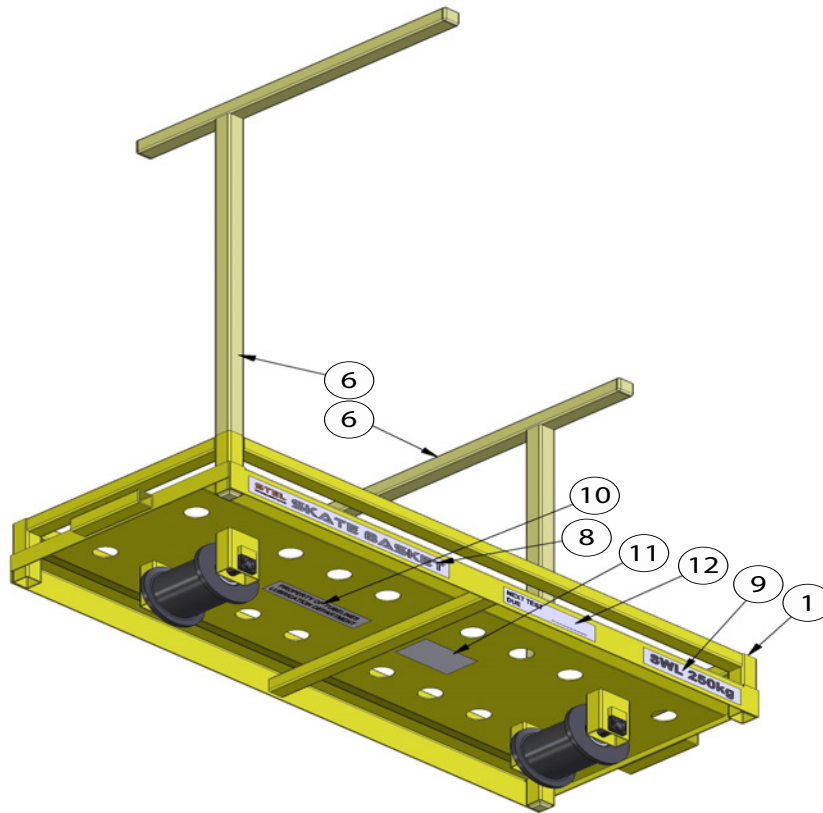

Pos;	Part No;	Description;	Qty;
1	SBC-FR-LU	Skate Basket Chassis (LU)	1
2	SBC-08	Skate Basket Roller	2
3	6302-2RS	Bearing	4
4	SPIN2-20	2 x 20Lg Split Pin	2
5	FWR-M16	M16 Flat Washer	2
6	SBC-HAN-LU	Skate Basket Handle	2
7	SBC-AXLE	Skate Basket Axle	2
8	SBC-LABEL01	Skate Basket Decal 330x30	2
9	SBC-LABEL03	SWL 75kg Label 150x30	2
10	SBC-LABEL02	Owner Label 150x30	1
11	SBC-LABEL04	Skate Basket Serial Label 85x50	1
12	NTD-LABEL	Next Test Due Label 150x30	1

**SKATE BASKET**

**NETWORK RAIL SPECIFIC**

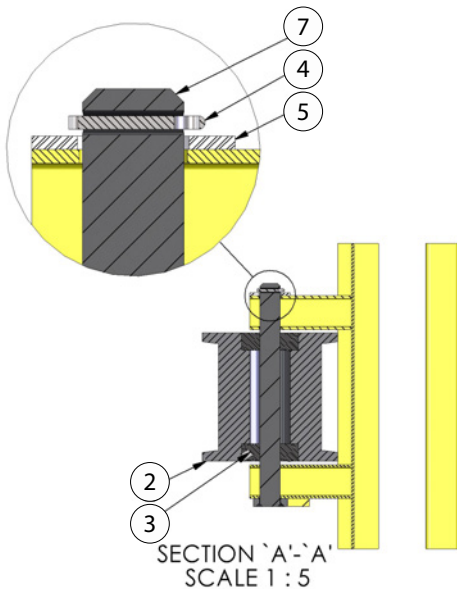
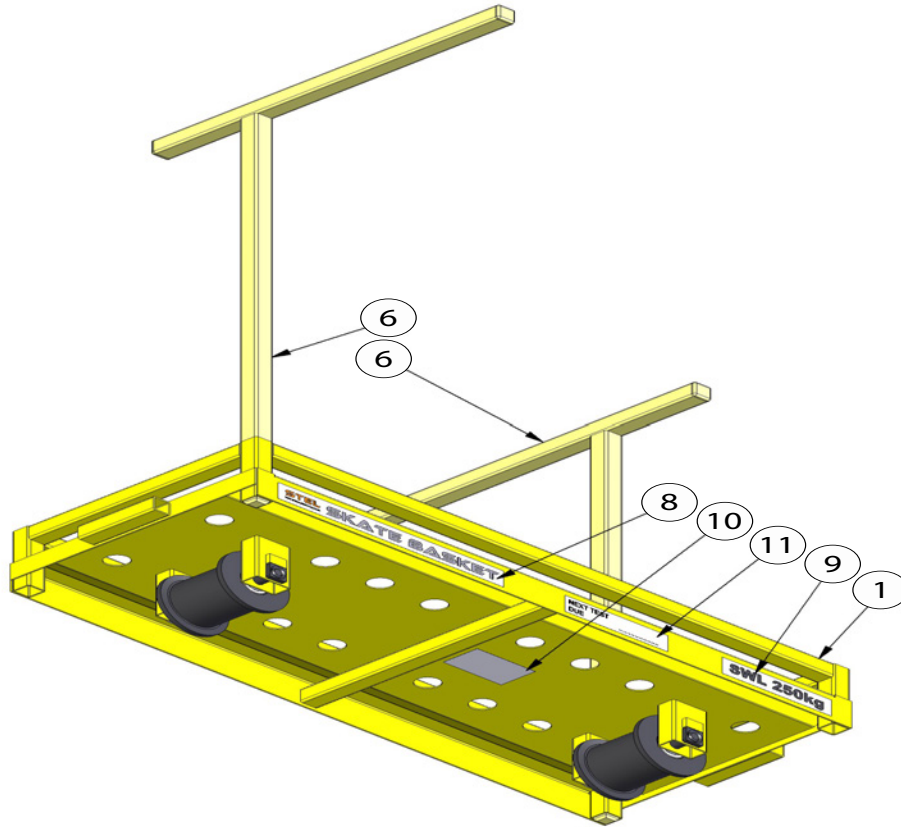

Pos;	Part No;	Description;	Qty;
1	SBC-FR-LU	Skate Basket Chassis (LU)	1
2	SBC-08	Skate Basket Roller	2
3	6302-2RS	Bearing	4
4	SPIN2-20	2 x 20 Lg Split Pin	2
5	FWR-M16	M16 Flat Washer	2
6	SBC-HAN-LU	Skate Basket Handle	2
7	SBC-AXLE	Skate Basket Axle	2
8	SBC-LABEL01	Skate Basket Decal	2
9	SBC-LABEL03	SWL 250kg Label	2
10	SBC-LABEL04	Skate Basket Serial Label	1
11	NTD-LABEL	Next Test Due Label	1

**IMPACT WRENCHES**

**Vessel GT350 Low Vibration Model**



Part No; GT350GES

Overall Dimension	
Without Damper	
Length	680mm (28")
Height	338mm (13")
Width	390mm (15")
With Damper	
Length	680mm (28")
Height	346mm (13")
Width	390mm (15")

Vibration	
Unloaded	
Without Damper	8.9 m/S2
With Damper	2.3m/S2
Loaded	
Without Damper	19m/S2
With Damper	11.6m/S2

Impact	
Square Driver Size	25.4mm (1")
Fastening Torque Range	1700 N.m (full throttle:1255 ft.lbf) 950 N.m (half throttle:701 ft.lbf)
Free Speed	1200rpm

Engine	
Type	Two Stroke, Forced, Air Cooled, Single Cylinder
Displacement	46.5cc 43x32mm (inner bore size x stroke)
Fuel Tank Capacity	1 Litre
Fuel Mixture Ratio	25:1 (gasoline:2 cycle oil)
Revolution (idling)	2700rpm +- 250
Revolution (loaded, impact)	7120rpm
Revolution (non loaded, max)	9880rpm
Ignition	Electronic
Spark Plug Type	NGK BPMR6A
Carburetor	Diaphragm



## IMPACT WRENCHES

### Vessel GT350 Standard Model



Part No; GT350GE

Overall Dimension	
Without Damper	
Length	680mm (28")
Height	338mm (13")
Width	390mm (15")
With Damper	
Length	680mm (28")
Height	346mm (13")
Width	390mm (15")

Vibration	
Unloaded	
Without Damper	8.9 m/S <sup>2</sup>
With Damper	2.3m/S <sup>2</sup>
Loaded	
Without Damper	19m/S <sup>2</sup>
With Damper	11.6m/S <sup>2</sup>

Impact	
Square Driver Size	25.4mm (1")
Fastening Torque Range	1700 N.m (full throttle:1255 ft.lbf) 950 N.m (half throttle:701 ft.lbf)
Free Speed	1200rpm

Engine	
Type	Two Stroke, Forced, Air Cooled, Single Cylinder
Displacement	46.5cc 43x32mm (inner bore size x stroke)
Fuel Tank Capacity	1 Litre
Fuel Mixture Ratio	25:1 (gasoline:2 cycle oil)
Revolution (idling)	2700rpm +/- 250
Revolution (loaded, impact)	7120rpm
Revolution (non loaded, max)	9880rpm
Ignition	Electronic
Spark Plug Type	NGK BPMR6A
Carburetor	Diaphragm



**RAIL SAW**

**Husqvarna K1270R Rail Saw**



Engine	
Output Power	5.8 kW
Cylinder Displacement	118.8 cm <sup>3</sup>
Electrode Gap	0.5 mm
Cylinders	1
Number of Strokes	2-stroke engine

Dimensions	
Product size length	730 mm
Product size width	243 mm
Product size height	434 mm
Weight	13.3 kg

Vibrations	
Vibrations left/front handle	6.9 m/s <sup>2</sup>
Vibrations right/rear handle	6.3 m/s <sup>2</sup>

Sound and Noise	
Sound power level, guaranteed (LWA)	117 dB(A)
Sound pressure level at operators ear	104 dB(A)

The K1270 16" saw package also includes the supply of a FOC 16" diameter genuine Husqvarna high performance diamond blade suitable for cutting concrete.

- \* Active Air Filtration increases life of filters by 3-5 times
- \* SmartCarb ensures high power is retained
- \* EasyStart provides 50% easier starts
- \* New magnesium blade guard - lighter in weight for an improved power-to-weight ratio
- \* Reduced wear thanks to the drive belt with fully sealed transmission, which keeps out the cutting dust

Cutting Equipment	
Cutting Depth, Max	118 mm
Blade Diameter, Max	350 mm
Arbor Diameter	20/25,4 mm
Blade Thickness, Max	5 mm
Peripheral Speed, Max	90 m/s

## CHAINSAW

### Stihl MS261CM Chainsaw



The Stihl MS 261 C-M is a lightweight and powerful, professional chainsaw. It has an electric self-tuning engine management system which means that the fuel supply is electronically controlled so the machine automatically adapts to operating conditions, ensuring optimal performance at all times. It has a memory function which will remember previous operating conditions and allows you to restart quickly after an extended break.

The 2-MIX technology ensures you can get up to 20% less fuel consumption and a 50% emissions reduction compared to other two-stroke engines that do not have 2-mix technology. This saw comes with an easy-clean HD2 filter, controlled delivery oil pump and other features such as a stainless steel muffler, captive nuts on the sprocket cover and monocoque cover with three quick release fasteners.

#### Standard features;

- STIHL M-Tronic
- HD2 filter
- Reduced-emission engine technology
- Advanced combustion technology
- Pre-separation air filtration system
- Anti-vibration system
- Carburettor heating
- STIHL ElastoStart
- Tool free filler caps
- Compensator
- Ematic chain lubrication system
- Side chain tensioner

#### Technical Data

Displacement cm <sup>3</sup>	50.2
Weight kg	5.2
Power-to-weight ratio kg/kW	1.79
Power output kW/bhp	2.9/3.9
Recomm. max. bar length cm	45
Vibration levels left/right m/s <sup>2</sup> 2)	3.5/3.5
Sound power level dB(A) 3)	116
Sound pressure level dB(A) 4)	104.0

## CHAINSAW

### Husqvarna 560XP Chainsaw



The Husqvarna 560XP professional petrol chainsaw from Husqvarna has an amazing design and is packed with product enhancing features such as AutoTune X-Torq engine with RevBoost and magnesium crankcase.

It has been designed with the professional forester in mind and it delivers outstanding, efficient power, guaranteed! The unique X-Torq engine technology provides more power where it is needed, up to 20% less fuel consumption and 75% less exhaust emissions. RevBoost provides instant high chain speed for extra efficient de-limbing. AutoTune gives optimal engine performance throughout with automatic engine setting when engine conditions change during use. No more time spent adjusting carburettors, AutoTune compensates for different fuels, altitude, humidity, temperature and clogging air filters.

#### Standard features;

- X-Torq
- AutoTune
- RevBoost
- Air Injection

Technical Data	
Engine Type	2-Stroke Air Cooled X-Torq – RevBoost
Weight Kg	5.8
Power Output Kw/Bhp	3.5kW / 4.7hp
Noise Level In Db(A) / Lwa	118
Fuel Tank Capacity	0.65 Lit
Vibrations	Front Handle: 2.7m/s <sup>2</sup> Rear Handle: 3.2m/s <sup>2</sup>
Fuel Type	Unleaded Petrol Oil Mix 50: 1
Engine Displacement Cc	59.8

## CHAINSAW CHAINS



Part Code	Description
21BPX064E	Oregon Chainsaw Chain, 15", 64 Links @ 0.325
21LPX064E	Oregon Chainsaw Chain, 15", 64 Links @ 0.325
22LPX067E	Oregon Chainsaw Chain, 16" Suits Ms261
22LPX62E	Oregon Chainsaw Chain, 15", Suits Ms261
95VPX064E	Oregon Chainsaw Chain, 15", @ 0.325
M75LPX066E	Oregon Chainsaw Chain, 3/8" X 1.6Mm, 66 Links



Part Code	Description
3616 000 0050	Stihl Chainsaw Chain, 14", 50 Links, 1.3Mm X 3/8" Pitch
3621 000 0056	Stihl Chainsaw Chain, 15", 56 Links, 1.6Mm
3621 000 0066	Stihl Chainsaw Chain, 16", Suits Ms362c
3621 003 0056	Stihl Chainsaw Chain, 15", Suits Ms361, Ms290, Ms291
3636 000 0055	Stihl Chainsaw Chain, 16", 55 Links, Suits Ms210, Ms230
3636 003 0050	Stihl Chainsaw Chain, 14", Suits Ms181
3639 003 0062	Stihl Chainsaw Chain, 15", Suits Ms260, Ms261
3639 003 0067	Stihl Chainsaw Chain, 16", Suits Ms260, Ms261
3652 003 0056	Stihl Chainsaw Chain, 15", Suits Ms290
3667 000 0067	Stihl Tungston Tipped Chainsaw Chain, 16", 67 Links
3670 000 0064	Stihl Chainsaw Chain, 12", Suits Ht101, Ms150t
3943 000 0060	Stihl Tungston Tipped Chainsaw Chain
4242 710 6001	Stihl Chainsaw Chain, 22", Suits Hs46



Part Code	Description
501 84 04-64	Husqvarna Chainsaw Chain, 15", 64 Links, Suits 550Xp
501 84 06-64	Husqvarna Chainsaw Chain, 15", Suits H30, 445
501 84 06-72	Husqvarna Chainsaw Chain, Suits H30
505 51 34-53	Husqvarna Chainsaw Chain, 15", 64 Links, Suits 353, 325
505 51 34-55	Husqvarna Chainsaw Chain, Suits 2165



Part Code	Description
958492656	Makita Chainsaw Chain, 16", 56 Links
MAK14CHAIN	Makita Chainsaw Chain, 16", 52 Links

Upon Enquiry Different Size Chains May Be Available / Able To Be Sourced



## CHAINSAW GUIDE BARS

**STIHL**<sup>®</sup>

Part Code	Description
3003 000 5306	Stihl Guide Bar, 13", Suits Ms261
3003 000 6811	Stihl Guide Bar, 15", Suits Ms261
3003 000 6813	Stihl Guide Bar, 16", Suits Ms261
3003 008 6817	Stihl Guide Bar, 18", Suits Ms261
3005 000 4809	Stihl Guide Bar, 14" Rollomatic
3005 000 4813	Stihl Guide Bar, 16", Suits 023

**Husqvarna**<sup>®</sup>

Part Code	Description
508 92 61-64	Husqvarna Guide Bar, 15", Suits 350, 445
585 94 33-64	Husqvarna Guide Bar, 15", Suits 346Xp
585 95 08-56	Husqvarna Guide Bar, 15", Suits 365



## BERNARD ENGINE

### Bernard Engine

Compatible With The Geismar MP12 Profile Grinder



Part No; 2115006

Bernard Engine Technical Information	
Rotation	Anti Clockwise (Outlet Side)
Compression	Centrifugal Mechaninc Type
Governor System	Centrifugal Mechaninc Type
Starting System	Recoil Starter
Air Cleaner	Dual Element (Moss and Cartridge)
Displacement	213 cm3
Compression Rate	8,0;1
Cylinder Bore x Stroke	73 x 51 MM
Max, Output Power	7 Hp - 4000Rpm
Max, Torque	1,4 Kgm - 3200 Rpm
Fuel Consumption	312 G/Kwh
Oil Capacity	0.7 Litres
Dimensions L x W x H	275 x 350 x 365MM

The MP12 Frame Not Included!

**BERNARD ENGINE SPARES**



**Bernard Engine  
211-5006  
Ignition Coil**

Part No; 18111050



**Bernard Engine  
211-5006  
Piston Ring Set 73Ø**

Part No; 21102030



**Bernard Engine  
211-5006  
Carburettor**

Part No; 21504410



**Bernard Engine  
211-5006  
Recoil Starter**

Part No; 21506360



**Bernard Engine  
211-5006  
Complete Gasket Set**

Part No; 21102030



**Bernard Engine  
211-5006  
Runner Mounting**

Part No; 21506360



**Bernard Engine  
211-5006  
Inlet Gasket**

Part No; 181050090

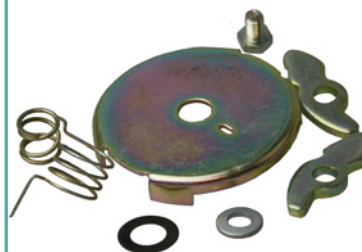

**Bernard Engine  
211-5006  
Kit Repair**

Part No; 18109040



**Bernard Engine  
211-5006  
Spark Plug Cap**

Part No; 18111020

## GENERATORS

**Harrington Generators**  
**2.4kW (3 kVA) Network Rail Approved**



**Rail Specific Generator With Genuine Honda GX200 Engine And Sincro Alternator  
Output - 2 x 16 Amp 110v Sockets**

Engine Specification	
Model	Honda GX160
Starting System	Recoil
Speed	3000rpm
Fuel Tank Capacity	11ltr
Run Time (75% Load)	9 Hours
Cooling System	Forced Air Cooled
Sockets Specification	
Standard	2 x 16Amp
Optional Configuration	1 x 16/1 x 32 Amp
Voltages	110Volts
Frequency	50Hz
Rated Output	2.4kW (3.0kVA)

Part No; HPR24-RAIL-S



## GENERATORS

### Stephill Generators

2.7 kVA / 2.2 kW Network Rail Approved



Engine Specification	
Engine	Honda GX160
Emissions Certified	N/A
Cylinders	Single
Distrubution	O.H.V
Aspiration	Normally Aspirated
Cooling	Air
Displacement	163 cm <sup>3</sup>
Rpm	3000
Starting system	Recoil
Fuel	Unleaded

Generator Specification	
Voltage	110V (55V/55V) CTE
Phase	1
Frequency	50Hz
Prime Power (PRP)	2.7 kVA / 2.2 kW
Aspiration	Normally Aspirated
Alternator	NSM K100C
Alternator Type	Brushless - Smooth Waveform
Fuel tank capacity	11.0 Litres
Autonomy 75% load	11.0 Hours
LWA	95
dBA @ 7M	70

Part No; GENNY1

## GENERATORS

### Stephill Generators

2.7kW / 3.4 kVA Network Rail Approved



Engine Specification	
Engine	Honda GX160
Emissions Certified	N/A
Cylinders	Single
Distribution	O.H.V
Aspiration	Normally Aspirated
Cooling	Air
Displacement	193 cm <sup>3</sup>
Rpm	3000
Starting system	Recoil
Fuel	Unleaded

Part No; GENNY

Generator Specification	
Voltage	110V (55V/55V) CTE
Phase	1
Frequency	50Hz
Prime Power (PRP)	3.4 kVA / 2.7 kW
Aspiration	Normally Aspirated
Alternator	NSM K1000D
Alternator Type	Brushless - Smooth Waveform
Fuel tank capacity	11.0 Litres
Autonomy 75% load	9.1 Hours
LWA	96
dBA @ 7M	71



**DUST SUPPRESSION WATER BOTTLE & PUMP BOTTLE**



**Complete Water Bottle  
14 Ltr Capacity**

**Part No; 71800**



**Water Hose 3/8" PVC 4  
Metres**

**Part No; 71806**



**Water Bottle Hose Nut  
Fitting**

**Part No; 71810**



**Water Bottle Hose Nipple  
Fitting**

**Part No; 71811**



**Hose Connector 1/2" Quick  
Release External Auto Stop**

**Part No; 71815**



**Hose Connector 1/2" Quick  
Release Internal Auto Stop**

**Part No; 71816**



**Water Bottle Pump (Black)**

**Part No; 71820**



**Water Bottle Pressure Valve  
(Black)**

**Part No; 71821**



**Pump Bottle To Fit STEL's  
Rail Drill & Cembre  
Rail Drill 5Ltr Complete**

**Part No; PUMPBC**



**RAIL DRILL**



**TCT Cutters**  
Code: TCTR30S (30mm TCT Cutter)  
Code: TCTR22S (22mm TCT Cutter)



**M42 Cutters**  
Code: CRC22S (30mm M42 Cutter)  
Code: CRC30S (32mm M42 Cutter)

(Alternate sizes available on request)



**STEL Opticut Soluble Semi Synthetic Cutting Oil**  
Code: 200102 (5 Litre)  
Code: 200104 (20 Litre)

**STEL Opticut Soluble Bio-degradable Cutting Oil**  
Code: 200100 (5 Litre)  
Code: 200101 (20 Litre)



**STEL Coolant Pump Bottle (5 Litre Capacity)**  
Code: 100003



**STEL Magnetic Swarf Collector**  
Code: 100071



**STEL Rail Drill Positioning Jig (UIC 60)**  
Code: 100011

(Alternate jigs available on request)



**STEL Rail Drill Shoe (UIC 60)**  
Code: 100008  
(Alternate shoes available on request)



**STEL Axle Counter Positioning Jig**  
Code: 100019

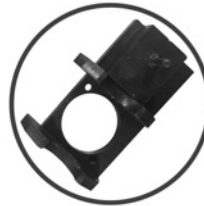

**STEL Bond Positioning Jig (UIC 60) - (7.2mm Hole)**  
Code: 100021



**STEL Bond Bit Adaptor**  
Code: 13MMBONDBITADAP (13mm Bond Bit)  
Code: 38BONDBITADAP (9.52mm / 3/8" Bond Bit)  
Code: 932BONDBITADAP (7.2mm / 9/32" Bond Bit)



**STEL Bond Bit**  
Code: 38BONDBIT (9.52mm / 3/8" Bond Bit)  
Code: 932BONDBIT (7.2mm / 9/32" Bond Bit)



**STEL Battery Rail Drill 12Ah Battery**  
Code: 100007



**STEL Battery Rail Drill M18 Mains Charger**  
Code: 100005



**STEL Battery Rail Drill M18 Vehicle 12V Charger**  
Code: 100006



**STEL Battery Rail Drill M18 6 Bay Mains Multi Charger**  
Code: 100042 (240V)  
Code: 100041 (110V)



**STEL Battery Rail Drill Storage Case**  
Code: 100002

## MAGIC WAND

# MAGNETIC SWARF COLLECTOR

Magnetic Retrieving Batons are Innovative and Powerful Tools to Remove Ferrous Materials in Wet or Dry Environments

**Key Features:**

Magnetic Retrieving Baton with Release

Non-Corrosive Stainless Steel

Ideal for Removing Hardware from Storage Bins

Clean Water or Degreasing Tanks of Metal Shavings

Unique Shape Allows for Easy Pick Up from Walls and Corners

Constructed with Neodymium / Rare Earth Magnets to Maximise Holding Power

Pull to Release Collected Materials to Dispose Of

*Use of Safety Goggles and Gloves is Highly Recommended when Using This Item*

### MAGNETIC SWARF COLLECTOR

Part No: MAGICWAND



Fabricating in Steel can be a Messy Business, We Have the Perfect Tool to Quickly Clean Up Your Metal Shavings and Scrap Pieces. Simply Wave the Magnetic Stick Over the Metal Shavings to Pick Them Up, Carry Them Over to Your Scrap Barrel, Pull The Plunger and The Shavings are Neatly Disposed. The Cyclones Magnet is Strong Enough to Quickly Clean Up Your Biggest Mess of Metal Shavings.

Easy to Pick up Components, Nuts, Bolts, Nails & Pins  
Easy Way of Picking Up Metals from Sawdust

**Length:** 400mm  
**Max Pick-Up:** 0.5 KG

## TRACK MAGNET

### TRACK MAGNET KEY YARDENE



Part No; YTMK

### STANDARD STRENGTH TRACK MAGNET - YELLOW



Part No; TRACMAGYEL



## YALE D85 PULL LIFT

### Yale D85 Pull Lift

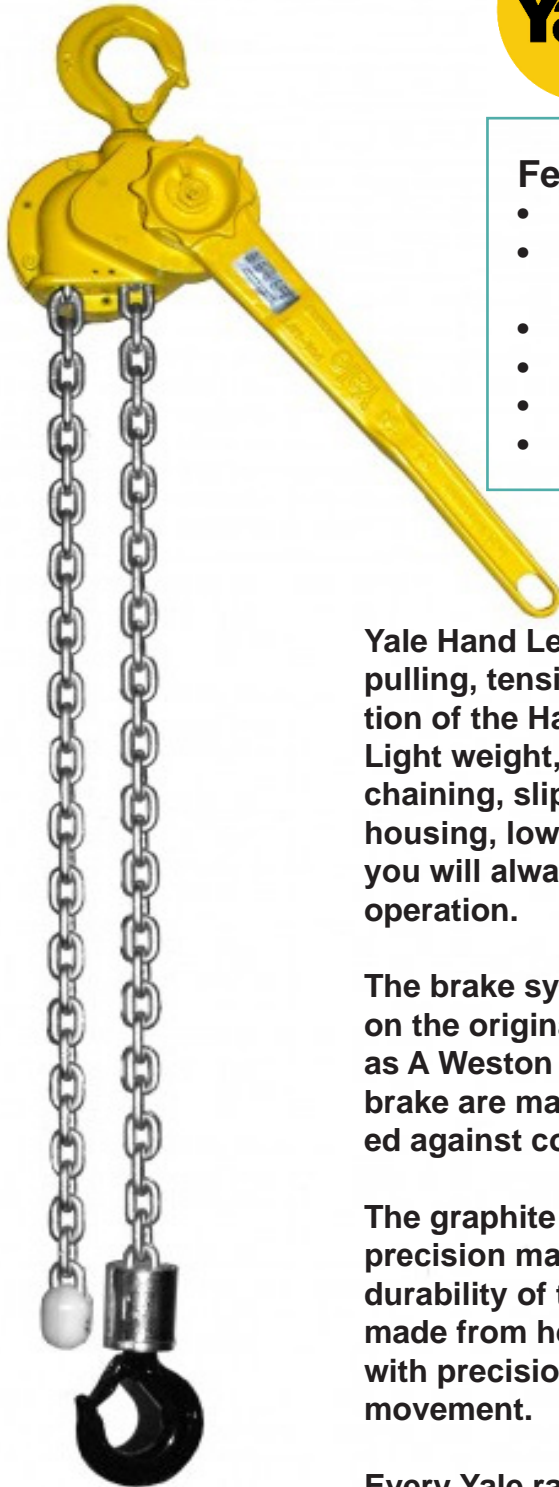

#### Features

- Graphite cast iron load sheave
- Hand lever made of malleable cast iron or tubular steel model with rubber grip
- Automatically acting load pressure brake
- Free chaining device optional
- Drop forged load and suspension hooks
- Asbestos-free friction discs

Yale Hand Lever Hoists are versatile, portable units for pulling, tensioning, lashing and lifting loads. The operation of the Hand Lever Hoists is easy and safe. Light weight, robust malleable cast iron model, free chaining, slip clutch, stamped steel - or aluminium housing, low operating effort - in the Yale product range you will always find an optimal hoist for every type of operation.

The brake system of all Yale hand lever hoists are based on the original Yale patent of the British Engineer Thomas A Weston dating back to 1875. All parts of the load brake are made of high quality materials and are protected against corrosion.

The graphite cast iron load sheave for the link chain has precision machined chain pockets for accurate fit and durability of the load chain. The roller chain sprocket is made from heat treated chromium-molybdenum steel with precision machine teeth to ensure smooth chain movement.

Every Yale ratchet lever hoist is factory tested with overload. The units are supplied with a test certificate showing the serial-No. Operating instructions which contain an EC declaration of conformity are also attached to each unit.

Part No; D85

**YALE D85 PULL LIFT**

**D85 Parts Manual**

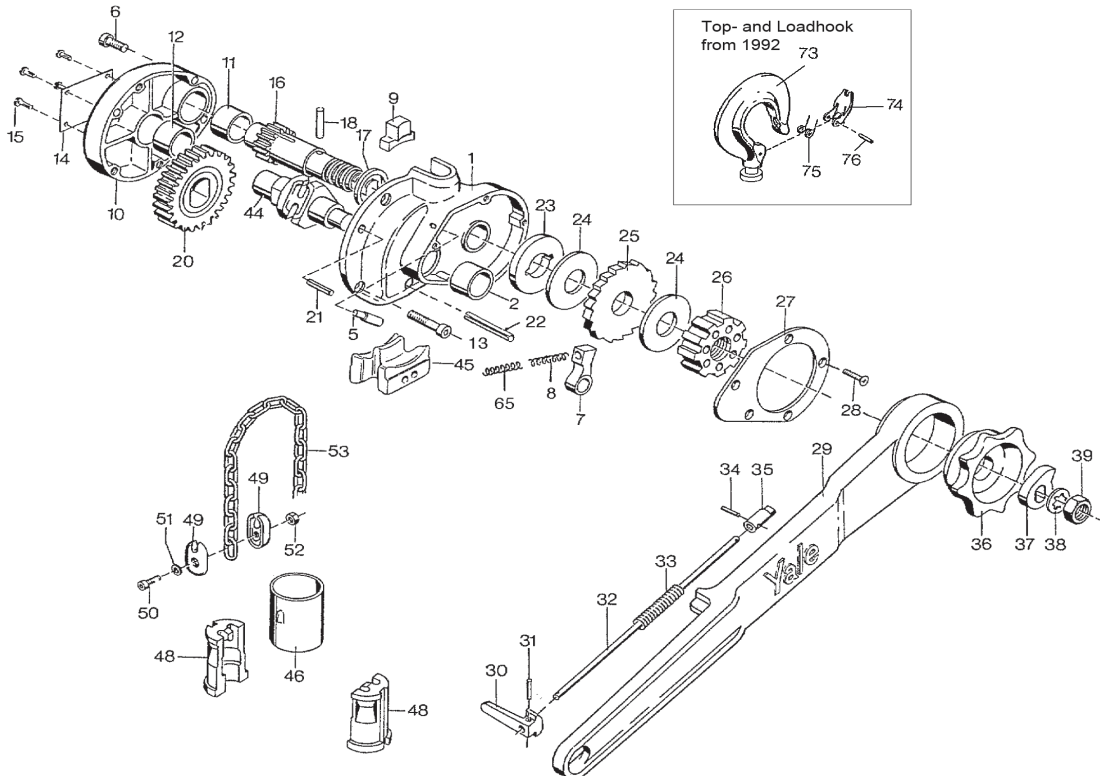

Parts for Model C 85 with roller chain

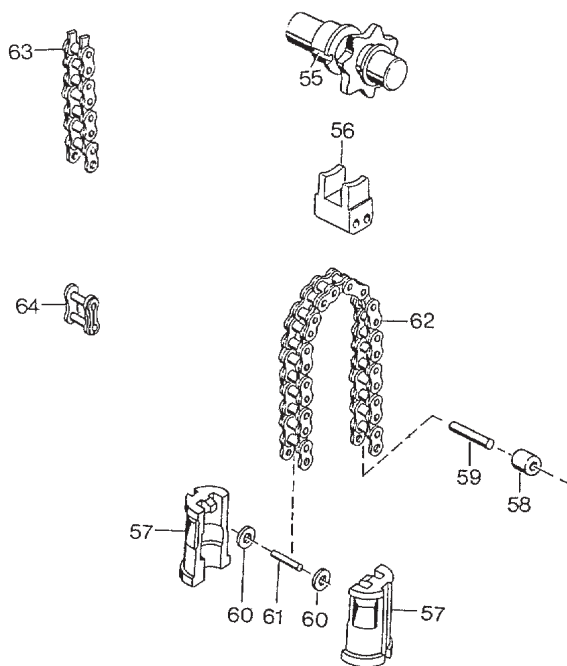

Parts for rubber grip lever (cpl.= No. 72)

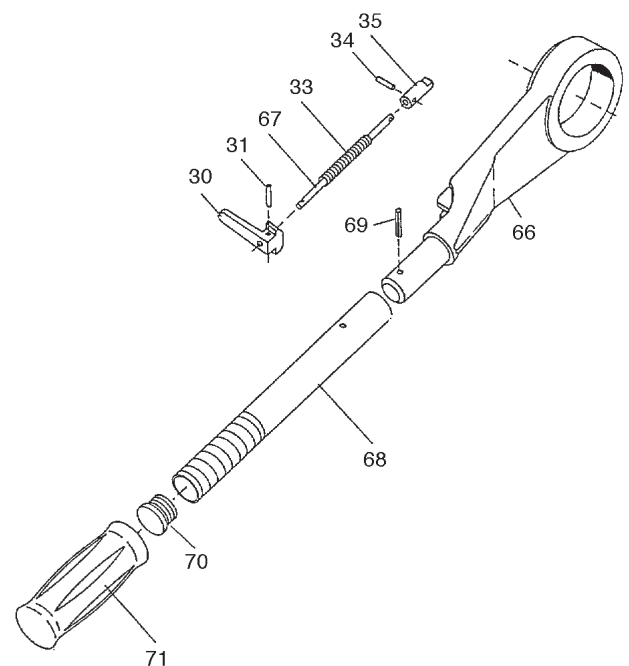

92 SMALL PLANT

YALE D85 PULL LIFT



D85 Parts List

Pos;	Part No;	Description;	Qty;
1-2+5-6	0106208	Housing Assy	1
2	0105930	Bushing	1
5	0105020	Brake pawl spring pin	1
6	9105005	Cyl. screw	2
7*	0108287	Brake pawl	1
8*	0105019	Brake pawl spring	1
9	0103205	Fitting piece	1
10-13	0106209	Housing cover assy	1
11	0102503	Bushing	1
12	0105930	Bushing	1
13	9105010	Cyl. screw	2
14	0107487	Name plate	1
15	9128008	Grooved nail	4
16	0103146	Drive pinion	1
17	0111017	Spacer	1
18	0106254	Bolt	1
20	0103806	Gear	1
21	9134028	Locking sleeve	2
22	9134003	Locking sleeve	2
23	0103895	Disc hub	1
24	0108500	Friction disc, asbestos-free	2
25	0105075	Ratchet disc	1
26	0101028	Ratchet	1
27	0106001	Load brake cover	1
28	9104116	Screw	5
29-35	0105969	Hand lever assy	1
29	0105939	Hand lever, 443 mm	1
30	0102135	Pawl rod lever	1

Pos;	Part No;	Description;	Qty;
31	0102136	Lever rod pin	1
32	0102131	Bushing	1
33	0102132	Lever pawl spring	1
34	0102134	Ratchet rod pin	1
35	0102133	Ratchet pawl	1
36	0102037	Hand wheel	1
37	0102038	Check washer	1
38	9123018	Tooth washer	1
39	9115059	Hex. nut	1
40-43	0100916	Hook assy	2
41-43	0106371	Safety latch kit	2
46	0106048	Swivel tube	1
65	0108251	Brake pawl spring	1
66	0107660	Lever head	1
67	0107666	Ratchet rod	1
68	0107730	Tube	1
69	9134094	Locking sleeve	1
70	0108351	Plug	1
71	0246418	Grip	1
72	0108787	Rubber grip lever, cpl	1
73-76	0108247	Hook, cpl. (from 1992)	2
74-76	0109081	Safety latch kit	2

## YALE D85 PULL LIFT

### Parts For Model D85 With Roller Chain Only

Pos;	Part No;	Description;	Qty;
40-43,46, 57	0100365	Bottom Block Assy	1
55	0105900	Sprocket Wheel	1
56	0105917	Stripper	1
57	0100382	Swivel Half	2
58-59	0106233	Chain Stop Assy	1
58	0105914	Chain StopWW	1
59	0105986	Chain Bolt	1
60	0105588	Chain Washer	2
61	0105986	Chain Bolt	1
63	1245700	Load Chain, (Specify Length)	
58-62	1205956	Load Chain, Length 1,73 M	1
64	0106079	Chain Lock	1

### Parts For Model D85 With Link Chain Only

Pos;	Part No;	Description;	Qty;
40-43 + 46-48	0100311	Bottom block assy	1
44	0103805	Load sheave	1
45	0105697	Stripper	1
48	0100173	Swivel half	2
49-52	0104640	Chain stop assy	1
49	0104631	Chain stop half	2
50	9102103	Cyl. screw	1
51	9122032	Lockwasher	1
52	9115014	Hex. nut	1
53	1607645	Load chain zinc coat. (specify length)	

## WILLIAM HACKETT L5 LEVER HOIST



**William Hackett**

### William Hackett L5 Lever Hoist



The Hackett WH-L5 lever hoist meets and exceeds the requirements of international standards BS EN13157:2004 + A1:2009, ASME B30.21-2014, AS1418.2-1997, SANS 1636:2-2007. Lever hoists can be used within an operating temperature range of -40°C to +55°C.

#### Features

- **Range: 800Kg To 10 Tonnes.**
- **Light Load Capability: The Wh-L5 Is Tested And Certified At 2% Of The Lever Hoist Rated Capacity.**
- **Safety Latches: Wh-L5 Lever Hoist Top And Bottom Hooks Are Fitted With Heavy Duty Cast Steel Latches Creating A Strong And Robust Hook Closure.**
- **Overload Indicator Marks: Wh-L5 Lever Hoist Top And Bottom Hooks Have, As Part Of The Hook Forging, An Overload Indicator Mark Either Side Of The Hook Throat. By Measuring The Distance Between The Indicator Marks, The Hook Can Be Quickly And Easily Checked To See If Any Stretch Has Occurred Due To Misuse Or Overloading.**
- **Overload Limiter: Available As An Option Upon Request.**
- **Hook Housing: Wh-L4 Lever Hoist Top And Bottom Hook Housing Are Secured With Socket Head Cap Screws/Hex Head Bolts And Nyloc Insert Locking Nuts.**
- **Fleeting/Cross Hauling: Wh-L5 Lever Hoists Are Tested And Certified For Fleeting Or Cross Hauling Applications Up To 45° From The Vertical Without Deration.**



**WILLIAM HACKETT L5 LEVER HOIST**

**William Hackett L5 Lever Hoist Parts Manual**

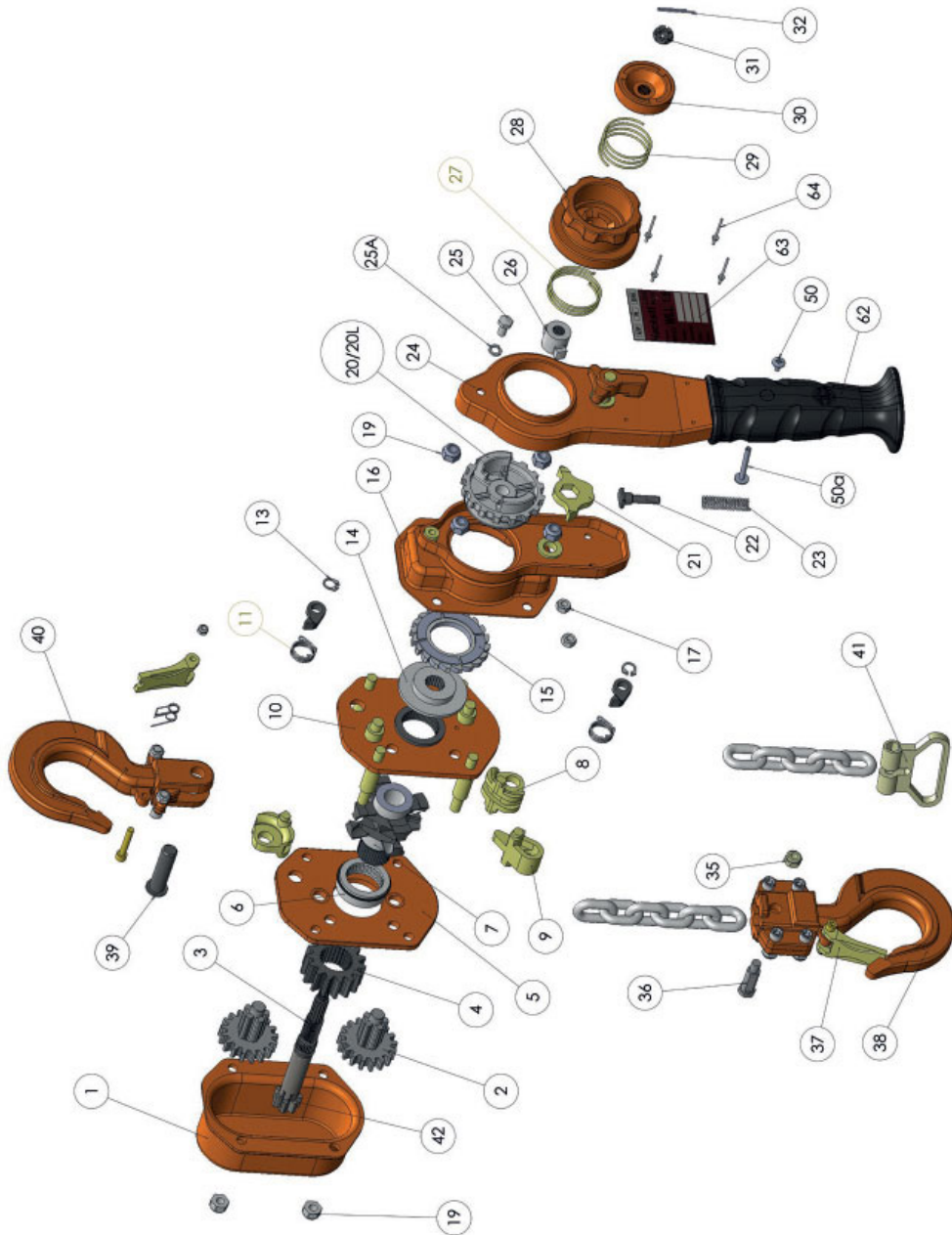

## WILLIAM HACKETT L5 LEVER HOIST



### William Hackett L5 Lever Hoist Parts List

Pos;	Part No;	Description;
1	L5.01	Gear cover
2	L5.02	Pinion gear
3	L5.03	Pinion shaft
4	L5.04	Load gear
5	L5.05	Gear side plate assembly
6	L5.06	Bearing
7	L5.07	Load sheave
8	L5.08	Chain guide
9	L5.09	Chain stripper
10	L5.10	Lever Side plate assembly
11	L5.11	Pawl spring
12	L5.12	Pawl
13	L5.13	Circlip
14	L5.14	Disc Hub
15	L5.15	Ratchet gear c/w discs
16	L5.16	Brake cover assembly
17	L5.17	Nyloc Nut
19	L5.19	Nyloc Nut
20	L5.20	Change gear
20L	L5.20L	Load limiter
21	L5.21	Change over pawl
22	L5.22	Change over stand
23	L5.23	Change over spring

Pos;	Part No;	Description;
24	L5.24	Handle assembly
24A	L5.24A	Rubber handle
25	L5.25	Screw
25A	L5.25A	Washer
26	L5.26	Cam
27	L5.27	Spring
28	L5.28	Grip ring
29	L5.29	Spring
30	L5.30	Spring housing
31	L5.31	Castle nut
32	L5.32	Split pin
34	L5.34	Label
35	L5.35	Lock nut
36	L5.36	Chain fixing pin
37	L5.37	Latch kit
38	L5.38	Bottom hook assembly
39	L5.39	Top hook shaft
40	L5.40	Top hook assembly
41	L5.41	End stop (cast enlarged)
42	L5.42	Washer
47	L5.47	Chain fixing pin
48	L5.48	Nut
50	L5.50	Rubber handle nut
50A	L5.50A	Rubber handle bolt

**LIFTING & CLAMPS**

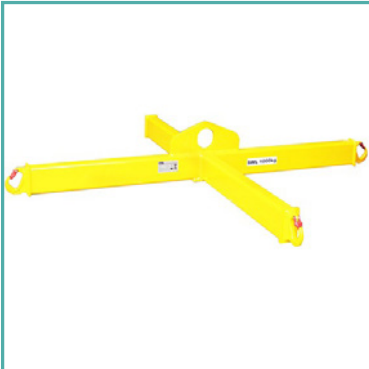

**Bag Lifter - 1 Tonne**

Part No; BAGLIFT

**Features**

- The Bag Lifter - 900mm to 970mm 1000kg SWL
- The bag lifter is designed to lift and transport large bags safely and securely.
- Manufactured as a 4 point spreader beam in a fixed frame, the construction incorporates 4 hooks with safety latches allowing fast and efficient loading and unloading.
- The bag lifter is suitable for bags 900mm to 970mm wide and can hold a maximum weight of 1 tonne.



**Camlok Lifting Clamp**

Part No; CR1000

**Features**

- The CR Rail clamps are designed to lift single rails securely and safely. The clamp is designed to fit most types of rail section sizes currently in use.
- The clamp has a narrow profile to enable attachment to an individual rail that is stacked side by side with other rails. The clamp is locked onto the rail-head via a lever operated spring mechanism.
- It is recommended to use clamps suspended from a lifting beam for long rail lengths.



**150LB Conductor Rail Clamp**

Part No; CRCL



**U69 Check Rail Clamp**

Part No; U69CRC



**Universal Rail Clamp**

Part No ; URC

# INDEX BY PRODUCT

## ABRASIVES

14" Inch Klingspor Rail Cutting Disc.....	36
14" Inch Tyrolit Rail Cutting Disc.....	36
16" Inch Klingspor Rail Cutting Disc.....	36
16" Inch Tyrolit Rail Cutting Disc.....	36
Cup Stone To Suit Geismar Mv3 Grinder.....	36
Diamond Blade, Vacuum Brazed 400mm x 200mm Bore.....	36
Rail Disc Carrying Bag.....	36
Replacement Geismar Mc3 Frog Stone.....	36
Replacement Geismar Mp12 Grinding Stone.....	36

## AUGERS

10mm x 240mm to suit Maxim Auger Attachment.....	16
10mm x 290mm Geismar Type.....	16
10mm x 320mm to suit Cembre Sleeper Drill.....	16
11mm x 240mm to suit Maxim Auger Attachment.....	16
12mm x 240mm to suit Maxim Auger Attachment.....	16
12mm x 320mm to suit Cembre Sleeper Drill.....	16
13mm x 240mm to suit Maxim Auger Attachment.....	16
13mm x 320mm to suit Cembre Sleeper Drill.....	16
16mm x 240mm to suit Maxim Auger Attachment.....	16
16mm x 290mm Geismar Type.....	16
16mm x 320mm to suit Cembre Sleeper Drill.....	16
17mm x 240mm to suit Maxim Auger Attachment.....	16
17mm x 320mm to suit Cembre Sleeper Drill.....	16
18mm x 240mm to suit Maxim Auger Attachment.....	16
18mm x 320mm to suit Cembre Sleeper Drill.....	16
19mm x 240mm to suit Maxim Auger Attachment.....	16
19mm x 290mm Geismar Type.....	16
19mm x 320mm to suit Cembre Sleeper Drill.....	16
21mm x 240mm to suit Maxim Auger Attachment.....	16
21mm x 320mm to suit Cembre Sleeper Drill.....	16
22mm x 240mm to suit Maxim Auger Attachment.....	16
22mm x 320mm to suit Cembre Sleeper Drill.....	16

## BATTERIES

Varta Gel Filled Battery o Suit Wacker Plated52.....	37
Varta 12V 8.6Ah Motorcycle Battery.....	37
Energy 663 Greenmech Chipper 12V 110Ah 680 CCA Battery.....	37
Varta Battery 15 Greenmech Chipper12V 110Ah 680 CCA.....	37
Varta Battery G2 12V 20Ah.....	37
Varta Anti-Vibration Anti-Spill 815 Cranking Amps 50Ah.....	37
Tower Light Battery 45Ah 12V (MOSA 6000SX/GS).....	37
Varta Battery D24, 60Ah, 12V.....	37
Varta D59 Battery 12V, 60Ah 540CCA Suits TL90 Light Tower.....	37
Varta Battery Blue Dynamics E24, 70Ah, 12V Suits Mk4, TL90.....	37
Varta Battery 12V, 44Ah (VTI Tower Light / Timberwolf Chippers) ...	37
Varta 508901 Battery 12V 8Ah 150A.....	37
Varta Battery Heavy Duty Marine 140Ah 12V.....	37
Lantern Battery NX Zinc 7Ah, 6V.....	37
Arcgen Battery Welder Gen 8Ah, 12V YTX9-BS.....	37
Mini Eros Board Early Warning Battery Only.....	37
20 Watt Battery Light.....	37
Battery Pack For Mini Eros Board.....	37
M18 9.0Ah Red Lithium-Ion Battery.....	37
Lantbat.....	30

## BREAKERS

18" Long Chisel (3").....	17
300mm/12".....	17
380mm/ 15".....	17
380mm/ 15".....	17
450mm/ 18".....	17
450mm/ 18".....	17
Asphalt Cutter.....	17
Clay Spade.....	17
Tamping Pad.....	17
TampingShank.....	17
TarmacCutter.....	17
Tie Tamper.....	17

## CUTTERS

Pilot Pin Long.....	14
Pilot Pin Short.....	14
Rotabroach M42 Rail Cutter Long Series 13mm.....	14
Rotabroach M42 Rail Cutter Long Series 15mm.....	14
Rotabroach M42 Rail Cutter Long Series 19mm.....	15
Rotabroach M42 Rail Cutter Long Series 20mm.....	15
Rotabroach M42 Rail Cutter Long Series 21mm.....	15
Rotabroach M42 Rail Cutter Long Series 22mm.....	15
Rotabroach M42 Rail Cutter Long Series 24mm.....	15
Rotabroach M42 Rail Cutter Long Series 25mm.....	15
Rotabroach M42 Rail Cutter Long Series 26mm.....	15
Rotabroach M42 Rail Cutter Long Series 28mm.....	15
Rotabroach M42 Rail Cutter Long Series 30mm.....	15
Rotabroach M42 Rail Cutter Long Series 32mm.....	15
Rotabroach M42 Rail Cutter Long Series 34mm.....	15
Rotabroach M42 Rail Cutter Short Series 13.5mm.....	15
Rotabroach M42 Rail Cutter Short Series 13mm.....	15
Rotabroach M42 Rail Cutter Short Series 14mm.....	15
Rotabroach M42 Rail Cutter Short Series 15mm.....	15
Rotabroach M42 Rail Cutter Short Series 17mm.....	15
Rotabroach M42 Rail Cutter Short Series 18mm.....	15
Rotabroach M42 Rail Cutter Short Series 19mm.....	15
Rotabroach M42 Rail Cutter Short Series 20mm.....	15
Rotabroach M42 Rail Cutter Short Series 21mm.....	15
Rotabroach M42 Rail Cutter Short Series 22mm.....	15
Rotabroach M42 Rail Cutter Short Series 24mm.....	15
Rotabroach M42 Rail Cutter Short Series 25mm.....	15
Rotabroach M42 Rail Cutter Short Series 26mm.....	15
Rotabroach M42 Rail Cutter Short Series 27mm.....	15
Rotabroach M42 Rail Cutter Short Series 28mm.....	15
Rotabroach M42 Rail Cutter Short Series 29mm.....	15
Rotabroach M42 Rail Cutter Short Series 30mm.....	15
Rotabroach M42 Rail Cutter Short Series 31mm.....	15
Rotabroach M42 Rail Cutter Short Series 32mm.....	15
Rotabroach M42 Rail Cutter Short Series 33mm.....	15
Rotabroach M42 Rail Cutter Short Series 34mm.....	15
Rotabroach M42 Rail Cutter Short Series 36mm.....	15
Rotabroach TCT Rail Cutter Long Series 19mm.....	15
Rotabroach TCT Rail Cutter Long Series 22mm.....	15
Rotabroach TCT Rail Cutter Long Series 26mm.....	15
Rotabroach TCT Rail Cutter Extra Long Series 26mm.....	15
Rotabroach TCT Rail Cutter Long Series 27mm.....	15
Rotabroach TCT Rail Cutter Long Series 28mm.....	15
Rotabroach TCT Rail Cutter Extra Long Series 28mm.....	15



## CUTTERS

Rotabroach TCT Rail Cutter Long Series 30mm.....	15
Rotabroach TCT Rail Cutter Long Series 32mm.....	15
Rotabroach TCT Rail Cutter Short Series 13.5mm.....	15
Rotabroach TCT Rail Cutter Short Series 17mm.....	15
Rotabroach TCT Rail Cutter Short Series 19mm.....	15
Rotabroach TCT Rail Cutter Short Series 20mm.....	15
Rotabroach TCT Rail Cutter Short Series 21mm.....	15
Rotabroach TCT Rail Cutter Short Series 22mm.....	15
Rotabroach TCT Rail Cutter Short Series 24mm.....	15
Rotabroach TCT Rail Cutter Short Series 26mm.....	15
Rotabroach TCT Rail Cutter Short Series 28mm.....	15
Rotabroach TCT Rail Cutter Short Series 30mm.....	15
Rotabroach TCT Rail Cutter Short Series 32mm.....	15
Rotabroach TCT Rail Cutter Short Series 34mm.....	15
STEL M42 Rail Cutter Long Series 12mm.....	14
STEL M42 Rail Cutter Long Series 13mm.....	14
STEL M42 Rail Cutter Long Series 14mm.....	14
STEL M42 Rail Cutter Long Series 15mm.....	14
STEL M42 Rail Cutter Long Series 16mm.....	14
STEL M42 Rail Cutter Long Series 17mm.....	14
STEL M42 Rail Cutter Long Series 18mm.....	14
STEL M42 Rail Cutter Long Series 19mm.....	14
STEL M42 Rail Cutter Long Series 20mm.....	14
STEL M42 Rail Cutter Long Series 21mm.....	14
STEL M42 Rail Cutter Long Series 22mm.....	14
STEL M42 Rail Cutter Long Series 23mm.....	14
STEL M42 Rail Cutter Long Series 24mm.....	14
STEL M42 Rail Cutter Long Series 25mm.....	14
STEL M42 Rail Cutter Long Series 26mm.....	14
STEL M42 Rail Cutter Long Series 27mm.....	14
STEL M42 Rail Cutter Long Series 28mm.....	14
STEL M42 Rail Cutter Long Series 29mm.....	14
STEL M42 Rail Cutter Long Series 30mm.....	14
STEL M42 Rail Cutter Long Series 31mm.....	14
STEL M42 Rail Cutter Long Series 32mm.....	14
STEL M42 Rail Cutter Long Series 33mm.....	14
STEL M42 Rail Cutter Long Series 34mm.....	14
STEL M42 Rail Cutter Long Series 35mm.....	14
STEL M42 Rail Cutter Long Series 36mm.....	14
STEL M42 Rail Cutter Long Series 37mm.....	14
STEL M42 Rail Cutter Short Series 12mm.....	14
STEL M42 Rail Cutter Short Series 13mm.....	14
STEL M42 Rail Cutter Short Series 14mm.....	14
STEL M42 Rail Cutter Short Series 15mm.....	14
STEL M42 Rail Cutter Short Series 16mm.....	14
STEL M42 Rail Cutter Short Series 17mm.....	14
STEL M42 Rail Cutter Short Series 18mm.....	14
STEL M42 Rail Cutter Short Series 19mm.....	14
STEL M42 Rail Cutter Short Series 20mm.....	14
STEL M42 Rail Cutter Short Series 21mm.....	14
STEL M42 Rail Cutter Short Series 22mm.....	14
STEL M42 Rail Cutter Short Series 23mm.....	14
STEL M42 Rail Cutter Short Series 24mm.....	14
STEL M42 Rail Cutter Short Series 25mm.....	14
STEL M42 Rail Cutter Short Series 26mm.....	14
STEL M42 Rail Cutter Short Series 27mm.....	14
STEL M42 Rail Cutter Short Series 28mm.....	14
STEL M42 Rail Cutter Short Series 29mm.....	14
STEL M42 Rail Cutter Short Series 30mm.....	14
STEL M42 Rail Cutter Short Series 31mm.....	14
STEL M42 Rail Cutter Short Series 32mm.....	14
STEL M42 Rail Cutter Short Series 33mm.....	14
STEL M42 Rail Cutter Short Series 34mm.....	14
STEL M42 Rail Cutter Short Series 35mm.....	14
STEL M42 Rail Cutter Short Series 36mm.....	14
STEL M42 Rail Cutter Short Series 37mm.....	14
STEL TCT Rail Cutter Short Series 19mm.....	14
STEL TCT Rail Cutter Short Series 22mm.....	14

## CUTTERS

STEL TCT Rail Cutter Short Series 22mm.....	14
STEL TCT Rail Cutter Short Series 23mm.....	14
STEL TCT Rail Cutter Short Series 25mm.....	14
STEL TCT Rail Cutter Short Series 26mm.....	14
STEL TCT Rail Cutter Short Series 28mm.....	14
STEL TCT Rail Cutter Short Series 33mm.....	14

## CLAMPS & FISHPLATES

Emergency G - Clamp.....	45
Fassetta Bolt.....	46
Fassetta Clamp.....	46
Fishplates.....	45

## FUEL MANAGEMENT

10 Litre Jerry Can Black.....	21,23
10 Litre Jerry Can Green.....	21,23
10 Litre Jerry Can Red.....	21,23
10 Litre Jerry Can Yellow.....	21,23
10 Litre Jerry Can, Explosion Proof.....	25
10 Litre Screw Top Jerry Can Green.....	21,23
10 Litre Screw Top Jerry Can Red.....	21,23
10 Litre Screw Top Jerry Can Yellow.....	21,23
10 Ltr Plastic Container C/W Cap.....	25
20 Litre Jerry Can Black.....	21,23
20 Litre Jerry Can Blue.....	23
20 Litre Jerry Can Green.....	21,23
20 Litre Jerry Can Red.....	21,23
20 Litre Jerry Can Yellow.....	21,23
20 Ltr Plastic Container C/W Cap.....	25
5 Litre Jerry Can Black.....	22,23
5 Litre Jerry Can Green.....	22
5 Litre Jerry Can Red.....	22
5 Litre Jerry Can Yellow.....	22
5 Litre Jerry Can, Explosion Proof.....	22
5 Litre Plastic Jerry Can Black.....	22
5 Litre Plastic Jerry Can Green.....	24
5 Litre Plastic Jerry Can Red.....	24
5 Ltr Plastic Container C/W Cap.....	25
Jerry Can Flexible Spout Black.....	24
Jerry Can Flexible Spout Green.....	24
Jerry Can Flexible Spout Red.....	25
Jerry Can Flexible Spout Yellow.....	24
Jerry Can Rigid Spout Black.....	24
Jerry Can Rigid Spout Green.....	24
Jerry Can Rigid Spout Red.....	24
Jerry Can Rigid Spout Yellow.....	24
No Spill Fuel Spout Black.....	25
No Spill Fuel Spout Green.....	25
No Spill Fuel Spout Yellow.....	25

## LIGHTING

1.5 Kva, 240V TO 110V Dual Outlet Transformer.....	42
110V 16Amp Plug.....	42
110V 16Amp Socket.....	42
110V 32Amp Plug.....	42
110V 32Amp Socket.....	42
14M Extension Lead 110V 16 AMP 1.5MM.....	42
14M Extension Lead 110V 32 AMP 2.5MM.....	42
27W Led Rechargeable And Magnetic Work Light.....	44
3.3 Kva, 240V TO 110V Dual Outlet Transformer.....	42
4 Way Splitter Box 110V.....	42
40W Led Rechargeable And Magnetic Work Light.....	43
Lucia Link Light.....	41



## OILS

3 In 1 High Performance Lubricant.....	33
3 In 1 Oil Drip Applicator.....	33
3 In 1 Penetrant Spray.....	33
3 In 1 Ptfе Aerosol Spray.....	33
3 In 1 Silicone Lubricant.....	33
3 In 1 Spray.....	33
Anti-Fling Chainsaw Oil.....	33
Force Chain Lube Spray [6 Pk].....	33
Force Penetrating Fluid [6 Pk].....	33
Fully Synthetic Engine Oil 10W40.....	33
Gear Oil 80W90.....	33
Heavy Duty De-Greaser.....	33
Husqvarna Chainsaw Oil [Genuine].....	33
Hydraulic Grade T10 Oil.....	33
Hydraulic Grade T15 Oil.....	33
Hydraulic Grade T15 Oil.....	33
Hydraulic Grade T32 Oil.....	33
Hydraulic Grade T37 Oil.....	33
Hydraulic Grade T46b Oil.....	33
Hydraulic Grade T46b Oil.....	33
Indigear 60/80 Ep68 Oil.....	33
Motor Oil 10W30.....	33
Sae 30 Engine Oil.....	33
Semi-Synthetic Cutting Oil.....	33
Semi-Synthetic Engine Oil 10W40.....	33
Semi-Synthetic Engine Oil 15W40.....	33
Soluble Semi-Synthetic Cutting Oil.....	33
Transformer Non Conductive Oil.....	33
Two Stroke Fully Synthetic Oil.....	33
Two Stroke Oil.....	33
Two Stroke Semi-Synthetic Oil.....	33
Two Stroke SuperWW Oil.....	33
WD- 40 Spray.....	33

## PPE

Chainsaw Forestry Helmet.....	39
16" Leather Gaiters / Spats.....	40
60 Litre Heavy Duty Orange Nylon Kit Bag.....	40
Blue Canvas Tool Bag.....	40
Boston Safety Spectacles.....	40
Chainsaw Safety Gaiters.....	49
Chainsaw Safety Gloves (Large).....	39
Cut 5 Safety Gloves M, L, XL, XXL.....	38
Cut Resistant Sleeves.....	39
Dipped Nitrile Grip Gloves L, XL.....	38
Disposable Black Nitrile Gloves M, L, XL.....	38
Disposable Blue Nitrile Gloves S, M, L, XL.....	38
Disposable Orange Nitrile Grip Gloves M, L, XL.....	38
Disposable Powder Free Nitrile Gloves - Box Of 100.....	38
Elasticated Safety Goggles.....	40
Florida Safety Spectacles With Grey Lens.....	40
Grey Pu Palm Coated Gloves. S, M, L, XL.....	38
Hi-Vis Chainsaw Trousers (XL).....	39
Pura Ear Buds.....	40
Uvex Sulv Air Dust Mask.....	40

## PPE

Hi-Vis Orange Thinsulate Balaclava With Ear Mesh.....	39
Hi-Vis Quick Release Rucksack.....	39
Palm Coated Orange Gloves L, XL.....	38
Pan View Clear Safety Spectacles.....	40
Pura-Fit Disposable Earplugs 36Db - 20 Pairs.....	39
Red Ear Defenders.....	39
Thermo Star Gloves M, L, XL.....	38

## SIGNAGE

Amber Led Warning Light.....	30
Amber Lense Kit For Mk11 Marker Board ( C/W Fasteners).....	32
Battery Pack Plastic Case Only For Mini Eros Board.....	31
Blue Led Warning Light.....	30
Bullseye Temporary Speed Restriction Board 560mm x 300mm.....	29
Bullseye Temporary Speed Restriction Board 800mm x 300mm.....	29
Cancelling Indicator Board 390mm x 390mm.....	29
Directional Indicator Board 390mm x 390mm.....	29
Early Warning Mini Eros Board.....	31
Early Warning Mini Eros Board Free Standing.....	31
Lantern Battery.....	30
Led Mk11 Marker Board.....	31
Led Possession Limit Board.....	32
Led Stop Possession Limit Board.....	32
Led Stop Possession Limit Board With Rail Clamp.....	32
Mce Compact Worksite Marker Board.....	31
MCE Eros Battery Pack.....	31
Mk11 Marker Board Label - Engineers Supervisors Area Red.....	32
Mk11 Marker Board Label - PICOP Amber.....	32
Mk11 Marker Board Pcb Assembly Bottom.....	31
Mk11 Marker Board Possession Limit Board Switch Assembly.....	31
Mk11 Marker Board Thief Proof Bolt M6 x 91mm.....	31
Non Conductor Board Post 50mm x 50mm x 1800mm.....	29
Red Led Warning Light.....	30
Red Lense Kit For Mk11 Marker Board ( C/W Fasteners).....	32
Repeater Warning Temporary Speed Board 560mm x 660mm.....	29
Spatе Indicator Board 390mm x 390mm.....	29
Speed Board, 5 Mph, 390mm X 390mm.....	28
Speed Board, 10 Mph, 390mm X 390mm.....	28
Speed Board, 15 Mph, 390mm X 390mm.....	28
Speed Board, 20 Mph, 390mm X 390mm.....	28
Speed Board, 25 Mph, 390mm X 390mm.....	28
Speed Board, 30 Mph, 390mm X 390mm.....	28
Speed Board, 35 Mph, 390mm X 390mm.....	28
Speed Board, 40 Mph, 390mm X 390mm.....	28
Speed Board, 45 Mph, 390mm X 390mm.....	28
Speed Board, 50 Mph, 390mm X 390mm.....	28
Speed Board, 55 Mph, 390mm X 390mm.....	28
Speed Board, 60 Mph, 390mm X 390mm.....	28
Speed Board, 65 Mph, 390mm X 390mm.....	28
Speed Board, 70 Mph, 390mm X 390mm.....	28
Speed Board, 75 Mph, 390mm X 390mm.....	28
Speed Board, 80 Mph, 390mm X 390mm.....	28
Speed Board, 85 Mph, 390mm X 390mm.....	28
Speed Board, 90 Mph, 390mm X 390mm.....	28
Speed Board, 95 Mph, 390mm X 390mm.....	28
Speed Board, 100 Mph, 390mm X 390mm.....	28
Speed Board, 125 Mph, 390mm X 390mm.....	28
Temporary Speed Restriction Board 390mm x 390mm.....	29
Termination Indicator Board 390mm x 390mm.....	29
Tildawn Light, Blue Lens, Solid And Flashing.....	30
Tildawn Light, Red Lens, Solid And Flashing.....	30
Tilldawn Light, Red Solid Comes Fitted With A Rail Clamp.....	30

## SMALL PLANT

BERNARDENGINE.....	81
Bernard Engine 211-5006 Carburettor.....	82
Bernard Engine 211-5006 Ignition Coil.....	82
Bernard Engine 211-5006 Kit Repair.....	82
Bernard Engine 211-5006 Piston Ring Set 73Ø.....	82
Bernard Engine 211-5006 Complete Gasket Set.....	82
Bernard Engine 211-5006 Inlet Gasket.....	82
Bernard Engine 211-5006 Recoil Starter.....	82
Bernard Engine 211-5006 Runner Mounting.....	82
Bernard Engine 211-5006 Spark Plug Cap.....	82
Cembre Rail Drill Pump Bottle 5Ltr Complete.....	86
Complete Water Bottle.....	86
Harrington Generators 2.4kW (3 kVA).....	83
Hose Connector 1/2" Quick Release External Auto Stop.....	86
Hose Connector 1/2" Quick Release Internal Auto Stop.....	86
Husqvarna 560 XP Chainsaw .....	78
Husqvarna Chainsaw Chain, 15", 64 Links, Suits 353, 325.....	79
Husqvarna Chainsaw Chain, 15", 64 Links, Suits 550Xp.....	79
Husqvarna Chainsaw Chain, 15", Suits H30, 445.....	79
Husqvarna Chainsaw Chain, Suits 2165.....	79
Husqvarna Chainsaw Chain, Suits H30.....	79
Husqvarna Guide Bar, 15", Suits 346Xp.....	80
Husqvarna Guide Bar, 15", Suits 350, 445.....	80
Husqvarna Guide Bar, 15", Suits 365.....	80
Husqvarna K1270R Rail Saw .....	76
Impact Wrench Vessel Low Vibration.....	74
Impact Wrench Vessel Standard Model.....	75
Ironman London Underground.....	50
Ironman Network Rail.....	54
Link Trolley London Underground .....	64
Link Trolley Network Rail .....	67
Makita Chainsaw Chain, 16", 52 Links.....	79
Makita Chainsaw Chain, 16", 56 Links.....	79
Oregon Chainsaw Chain, 15", @ 0.325.....	79
Oregon Chainsaw Chain, 15", 64 Links @ 0.325.....	79
Oregon Chainsaw Chain, 15", 64 Links @ 0.325.....	79
Oregon Chainsaw Chain, 15", Suits Ms261.....	79
Oregon Chainsaw Chain, 16" Suits Ms261.....	79
Oregon Chainsaw Chain, 3/8" X 1.6Mm, 66 Links.....	79
Skate Basket.....	71
Split Trolley London Underground.....	58
Split Trolley Network Rail.....	61
STEL New and Improved Rail Drill.....	87
STEL Rail Drill Spare Parts.....	88
Stephill Generators 2.7 kVA / 2.2 kW.....	84
Stephill Generators 2.7kW / 3.4 kVA.....	85
Stihl Chainsaw Chain, 12", Suits Ht101, Ms150t.....	79
Stihl Chainsaw Chain, 14", 50 Links, 1.3Mm X 3/8" Pitch.....	79
Stihl Chainsaw Chain, 14", Suits Ms181.....	79
Stihl Chainsaw Chain, 15", 56 Links, 1.6Mm.....	79
Stihl Chainsaw Chain, 15", Suits Ms260, Ms261.....	79
Stihl Chainsaw Chain, 15", Suits Ms290.....	79
Stihl Chainsaw Chain, 15", Suits Ms361, Ms290, Ms291.....	79
Stihl Chainsaw Chain, 16", 55 Links, Suits Ms210, Ms230.....	79
Stihl Chainsaw Chain, 16", Suits Ms260, Ms261.....	79
Stihl Chainsaw Chain, 16", Suits Ms362c.....	79
Stihl Chainsaw Chain, 22", Suits Hs46.....	79
Stihl Guide Bar, 13", Suits Ms261.....	80
Stihl Guide Bar, 14" Rollomatic.....	80
Stihl Guide Bar, 15", Suits Ms261.....	80
Stihl Guide Bar, 16", Suits 023.....	80
Stihl Guide Bar, 16", Suits Ms261.....	80
Stihl Guide Bar, 18", Suits Ms261.....	80
Stihl Guide Bar, 22", Suits 550Mm.....	80
Stihl MS261CM Chainsaw.....	77
Stihl Tungston Tipped Chainsaw Chain.....	79
Stihl Tungston Tipped Chainsaw Chain, 16", 67 Links.....	79
Trolley Ramps.....	70
Water Bottle Hose Nipple Fitting.....	86

## SMALL PLANT

Water Bottle Hose Nut Fitting.....	86
Water Bottle Pressure Valve (Black).....	86
Water Bottle Pump (Black).....	86
Water Hose 3/8" PVC 4 Metres.....	86
Yale D85 Pull Lift.....	91
William Hackett Lever Hoist.....	95
Bag Lifter - 1 Tonne.....	98
Camlok Lifting Clamp.....	98
150LB Conductor Rail Clamp.....	98
U69 Check Rail Clamp.....	98
Universal Rail Clamp.....	98
Track Magnets.....	90
Magic Wand Swarf Collector.....	89

## SOCKETS

1/2" Drive Impact Sockets Hexagon 10mm.....	18
1/2" Drive Impact Sockets Hexagon 12mm.....	18
1/2" Drive Impact Sockets Hexagon 13mm.....	18
1/2" Drive Impact Sockets Hexagon 14mm.....	18
1/2" Drive Impact Sockets Hexagon 15mm.....	18
1/2" Drive Impact Sockets Hexagon 16mm.....	18
1/2" Drive Impact Sockets Hexagon 17mm.....	18
1/2" Drive Impact Sockets Hexagon 18mm.....	18
1/2" Drive Impact Sockets Hexagon 19mm.....	18
1/2" Drive Impact Sockets Hexagon 20mm.....	18
1/2" Drive Impact Sockets Hexagon 21mm.....	18
1/2" Drive Impact Sockets Hexagon 22mm.....	18
1/2" Drive Impact Sockets Hexagon 23mm.....	18
1/2" Drive Impact Sockets Hexagon 24mm.....	18
1/2" Drive Impact Sockets Hexagon 25mm.....	18
1/2" Drive Impact Sockets Hexagon 26mm.....	18
1/2" Drive Impact Sockets Hexagon 27mm.....	18
1/2" Drive Impact Sockets Hexagon 28mm.....	18
1/2" Drive Impact Sockets Hexagon 29mm.....	18
1/2" Drive Impact Sockets Hexagon 30mm.....	18
1/2" Drive Impact Sockets Hexagon 32mm.....	18
1/2" Drive Impact Sockets Hexagon 33mm.....	18
1/2" Drive Impact Sockets Hexagon 36mm.....	18
1/2" Drive Impact Sockets Hexagon 38mm.....	18
1/2" Drive Impact Sockets Hexagon 39mm.....	18
1/2" Drive Impact Sockets Hexagon 41mm.....	18
1/2" Drive Impact Sockets Hexagon 42mm.....	18
1/2" Drive Impact Sockets Hexagon 46mm.....	18
1/2" Drive Impact Sockets Hexagon 8mm.....	18
1/2" Drive X T50 Torx.....	19
1" Drive Bi-Square 1-11/16" X 1".....	18
1" Drive Bi-Square 1-3/16" X 1".....	18
1" Drive Bi-Square 1-3/8" X 1".....	18
1" Drive Bi-Square 1-5/16" X 1".....	18
1" Drive Impact Sockets Hexagon 16mm.....	18
1" Drive Impact Sockets Hexagon 17mm.....	18
1" Drive Impact Sockets Hexagon 18mm.....	18
1" Drive Impact Sockets Hexagon 19mm.....	18
1" Drive Impact Sockets Hexagon 20mm.....	18
1" Drive Impact Sockets Hexagon 21mm.....	18
1" Drive Impact Sockets Hexagon 22mm.....	18
1" Drive Impact Sockets Hexagon 23mm.....	18
1" Drive Impact Sockets Hexagon 24mm.....	18
1" Drive Impact Sockets Hexagon 25mm.....	18
1" Drive Impact Sockets Hexagon 26mm.....	18
1" Drive Impact Sockets Hexagon 27mm.....	18
1" Drive Impact Sockets Hexagon 28mm.....	18
1" Drive Impact Sockets Hexagon 29mm.....	18
1" Drive Impact Sockets Hexagon 30mm.....	18
1" Drive Impact Sockets Hexagon 31mm.....	18
1" Drive Impact Sockets Hexagon 32mm.....	18
1" Drive Impact Sockets Hexagon 33mm.....	18
1" Drive Impact Sockets Hexagon 34mm.....	18
1" Drive Impact Sockets Hexagon 35mm.....	18

## SOCKETS

1" Drive Impact Sockets Hexagon 36mm.....	18
1" Drive Impact Sockets Hexagon 37mm.....	18
1" Drive Impact Sockets Hexagon 38mm.....	18
1" Drive Impact Sockets Hexagon 39mm.....	18
1" Drive Impact Sockets Hexagon 40mm.....	18
1" Drive Impact Sockets Hexagon 41mm.....	18
1" Drive Impact Sockets Hexagon 42mm.....	18
1" Drive Impact Sockets Hexagon 43mm.....	18
1" Drive Impact Sockets Hexagon 44mm.....	18
1" Drive Impact Sockets Hexagon 45mm.....	18
1" Drive Impact Sockets Hexagon 46mm.....	18
1" Drive Impact Sockets Hexagon 50mm.....	18
1" Drive Impact Sockets Hexagon 55mm.....	18
1" Drive X T70 Torx.....	19
3/4" Drive X T70 Torx.....	19
Extension Bar 1" Drive Square X 300MM.....	20
Extension Bar 1" Drive X 250MM.....	20
Extension Bar 1" Drive X 300MM.....	20
Retaining Pins 45mm.....	18
Retaining Pins 50mm.....	18
Retaining Pins 55mm.....	18
Retaining Pins 60mm.....	18
Socket Adaptor - Square 1" Male X 3/4" Male.....	19
Socket Adaptor 1/2" Female X 1" Male.....	19
Socket Adaptor 1/2" Male X 1/2" Male.....	19
Socket Adaptor 1" Female X 1/2" Male.....	19
Socket Adaptor 1" Female X 3/4" Male.....	19
Socket Adaptor 1" Male X 1" Male.....	19
Socket Adaptor 3/4" Female X 1/2" Male.....	19
Socket Adaptor 3/4" Female X 1" Male.....	19
Socket Connector 3/4" Male X 3/4" Male.....	19
Socket Vossloh 28MM X 21MM X 1" Drive.....	18
Socket Vossloh 28MM X 21MM X 1/2" Drive.....	18
Socket Vossloh 28MM X 21MM X 3/4" Drive.....	18
Socket Vossloh 28MM X 21MM X 1" Drive 120MM.....	18
Socket Vossloh 28MM X 21MM X 1/2" Drive 90MM.....	18
Socket Vossloh 28MM X 21MM X 3/4" Drive 90MM.....	18
Universal Joint 1" Male X 1" Female.....	20

## SPARES

CHAMPION SPARK PLUG RCJ6Y.....	34
CHAMPION SPARK PLUG RCJ7Y.....	34
CHAMPION SPARK PLUG RCJ8.....	34
CHAMPION SPARK PLUG RL86C.....	34
Geismar Mp12 Drive Belt [Non Oem] UKG00923.....	35
Geismar Mp12 Toothed Drive Belt [Non Oem] UKG00923A.....	35
Husqvarna Drive Belt 506 07 05-07.....	35
Husqvarna K650 Drive Belt [Non Oem] BELT02.....	35
Husqvarna K750, K760 Drive Belt [Non Oem] BELT03.....	35
Kubota Rtv900 Wedge Drive Belt 17594-97010.....	35
NGK SPARK PLUG B2LM.....	34
NGK SPARK PLUG B6HS.....	34
NGK SPARK PLUG B6S.....	34
NGK SPARK PLUG BCPR5ES.....	34
NGK SPARK PLUG BCPR6ES.....	34
NGK SPARK PLUG BCPR7ES.....	34
NGK SPARK PLUG BCR8ES.....	34
NGK SPARK PLUG BKR5E.....	34
NGK SPARK PLUG BKR5EK.....	34
NGK SPARK PLUG BM6A.....	34
NGK SPARK PLUG BM7A.....	34
NGK SPARK PLUG BMR4A.....	34
NGK SPARK PLUG BMR6A.....	34
NGK SPARK PLUG BP5ES.....	34

## SPARES

NGK SPARK PLUG BP6ES.....	34
NGK SPARK PLUG BPM6A.....	34
NGK SPARK PLUG BPM6F.....	34
NGK SPARK PLUG BPMR4A.....	34
NGK SPARK PLUG BPMR6A.....	34
NGK SPARK PLUG BPMR7A.....	34
NGK SPARK PLUG BPMR8Y.....	34
NGK SPARK PLUG BPR4ES.....	34
NGK SPARK PLUG BPR5ES.....	34
NGK SPARK PLUG BPR5HS.....	34
NGK SPARK PLUG BPR6ES.....	34
NGK SPARK PLUG BPR6HS.....	34
NGK SPARK PLUG BR6HS.....	34
NGK SPARK PLUG CMR4A.....	34
NGK SPARK PLUG CMR5H.....	34
NGK SPARK PLUG CMR6A.....	34
NGK SPARK PLUG CMR6H.....	34
NGK SPARK PLUG CMR7H.....	34
NGK SPARK PLUG CR5HS.....	34
NGK SPARK PLUG CR5HSB.....	34
NGK SPARK PLUG CR9EH9.....	34
Stihl Ts410 Drive Belt [Non Oem] BELT05.....	35
Timberwolf Drive Belt [Non Oem] BELT06.....	35
Truemeter Rail Measure Drive Belt 102167-01.....	35

## SPILL MANAGEMENT

Absodan Absorbent Granules 20Ltr.....	26
Absorbent Pads Heavyweight 500MM X 400MM Qty 100.....	26
Absorbent Pads Lightweight 500MM X 400MM Qty 200.....	26
Absorbent Rolls Heavy Weight.....	26
Absorbent Socks Universal 75MM x 1.2M Qty 2.....	27
Isol8 Organic Absorbent Bag 1.3Kg.....	26
Multi-Zorb Absorbent Granules 20Ltr.....	26
Oil Spill Sheets Qty 200 500MM x 400MM.....	27
Plant Nappy Large 2000MM X 1370MM.....	27
Plant Nappy Liner Large.....	27
Plant Nappy Liner Medium.....	27
Plant Nappy Liner Small.....	27
Plant Nappy Medium 1000MM X 685MM.....	27
Plant Nappy Small 685MM X 500MM.....	27
Spill Control Kit 30 Litre Universal.....	27
Spill Kit, Emergency Oil, Vinyl Bag, 50 Ltr.....	26
Spill Kit, Emergency, Maintenance, Vinyl Bag, 50 Ltr.....	26
Spill Kit, Mini, Oil Only, 10 Ltr.....	26

## TRACK MEASURING

Analogue Rail Thermometer.....	47
Digital Rail Thermometer.....	47
Dual Track Trumeter Rail Measuring Wheel.....	48
Single Track Trumeter Rail Measuring Wheel.....	48

## TRACK TOOLS \*

Pandrol PR, E, E-Plus & RE Clips Pan Setter.....	1
15" Fishplate Nut Running Spanner .....	6
30" Fishplate Nut Locking Spanner.....	6
All Steel Extractor Ferrule.....	9
All Steel Pot Dolly Hexagon 17MM.....	8
All Steel Pot Dolly Hexagon 19MM.....	8
All Steel Square Pot Dolly 22MM For Wood.....	5
Cable Laying Shovel One Piece Handle.....	11
Chipping Shovel Insulated.....	11
Chisel & Point Crowbar.....	10
Clay Grafter Shovel One Piece Handle.....	11
Concrete Sleeper Tongs.....	4
Heavy Duty 1.7m Digging Bar.....	9
Heel & Point Crowbar.....	10
Heel & Point Crowbar (Round Shaft).....	10
Hickory Handle Keying Hammer - 10LB.....	13
Hickory Handle Keying Hammer - 7LB.....	13
Hickory Handle Sledge Hammer - 10LB.....	13
Hickory Handle Sledge Hammer - 14LB.....	13
Hickory Handle Sledge Hammer - 7LB.....	13
Insulated 1" T Drive Bar.....	6
Insulated 1-1/4" Jack Handle .....	7
Insulated Bi-Square Fishplate Nut Spanner .....	6
Insulated Check Rail Spanner - 1-11/16" AF X 30" .....	6
Insulated Chisel & Point Crowbar.....	10
Insulated Chisel End Crowbar.....	10
Insulated Concrete Sleeper Tongs.....	4
Insulated Digging Bar.....	9
Insulated Extractor Ferrule.....	9
Insulated Fishplate Spanner.....	6
Insulated Heel & Point Crowbar.....	10
Insulated Heel End Crowbar.....	10
Insulated Hook Switch Pole.....	6
Insulated Hydraclaw Jack Handle.....	6
Insulated Hydramite Jack Handle.....	6
Insulated Keying Hammer - 7LB OR 10LB .....	13
Insulated Pad Scraper.....	8
Insulated Pan Jack Handle.....	7
Insulated Pandrol E Clip & PR Clip Pan Puller .....	1
Insulated Pandrol E Clip Pan Setter.....	1
Insulated Pandrol E Plus Pan Puller.....	1
Insulated Pandrol Elastic Spike Extractor.....	1
Insulated Pandrol Fastclip Extractor.....	1
Insulated Pandrol Fastclip Installer .....	1
Insulated Pandrol Fastclip Sleeper Lifter.....	1
Insulated Pandrol Pan Lock Pan Puller.....	1
Insulated Pandrol Rear Arch Extractor.....	1
Insulated Point End Crowbar.....	10
Insulated Pot Dolly Hexagon 17MM For Concrete.....	8
Insulated Pot Dolly Square 22MM For Wood.....	8
Insulated Rail Turning Bar Bull Head Rail.....	5
Insulated Rail Turning Bar Flat Bottom.....	5
Insulated SHC De-Clipping Bar.....	5
Insulated Simplex 85A & Duff 516T Jack Handle.....	5
Insulated Simplex A17 Jack Handle.....	5
Insulated Sledge Hammer - 10LB.....	13
Insulated Sledge Hammer - 14LB.....	13
Insulated Sledge Hammer - 7LB.....	13
Insulated Steel Sleeper Tongs.....	4
Insulated T - Handled Chair Screw 1-1/8".....	9
Insulated Timber Nips.....	4
Insulated Timber Sleeper Tongs.....	4
Jack Handle Pan Jack, Toe Jack, Zwicky / Kenhi Handle.....	7

## TRACK TOOLS \*

Large Pad Scraper.....	8
Newcastle Draining Shovel One Piece Handle.....	11
Pandrol E Plus Pan Puller.....	2
Pandrol E Plus Pan Puller.....	2
Pandrol Fastclip & Vipa-Sp Installer.....	2
Pandrol Fastclip Extractor.....	2
Pandrol Fastclip FE/FC & Vipa-Sp Extractor .....	2
Pandrol Fastclip Installer.....	2
Pandrol Fastclip Sleeper Lifter.....	2
Pandrol FE/FC & Vipa-SP Installer .....	2
Pandrol Pan Lock Puller.....	2
Pandrol Rear Arch Extesnision Tool.....	2
Pandrol RT60 Check Rail Installer.....	2
Pandrol Spare Bolt For Pan Puller.....	2
Pandrol Spare Hook For C & D Pan Puller.....	2
Pandrol Spare Hook For E Plus Pan Puller.....	2
Pandrol Type C For PR & E-Clip Pan Puller.....	2
Pandrol Wear Gauge For Pan Puller Hook.....	2
Points Machine Winding Handle Cranked Suits Style 63 Points Machine.....	2
Rabbit Shovel One Piece Handle.....	11
Rail Tongs.....	4
Rail Turning Bar Bull Head Rail.....	5
Rail Turning Bar Flat Bottom.....	5
Round Mouth Shovel One Piece Handle.....	11
SCHWIHAG Bar.....	5
SHC De-Clipping Bar.....	5
Simplex A17 Jack Handle.....	7
Slewing Jack Handle Only.....	7
Small Pad Scraper.....	8
Square Mouth Shovel One Piece Handle.....	12
Steel Cable Laying Shovel.....	12
Steel Clay Grafter Shovel.....	12
Steel Newcastle Draining Shovel.....	12
Steel Rabbit Shovel.....	12
Steel Round Mouth Shovel.....	12
Steel Sleeper Tongs.....	4
Steel Square Mouth Shovel.....	12
Steel Taper Mouth Shovel.....	12
Steel Trenching Shovel.....	12
Stel's Point Machine Pump Handle Straight.....	5
T - Handled Chair Screw 1-1/8".....	9
Taper Mouth Shovel One Piece Handle.....	12
Timber Nips.....	4
Timber Sleeper Tongs.....	4
Trenching Shovel One Piece Handle.....	12
Thin Pad Scraper.....	8

## WHEEL BARROW

Insulated Wheel Barrow.....	49
-----------------------------	----

\* TOOLS FOR USE ON PANDROL FASTENING SYSTEMS



# TERMS & CONDITIONS

## SPECIALISED TOOLS AND EQUIPMENT LTD - T/A STEL : TERMS AND CONDITIONS FOR SALE OF GOODS

### 1. INTERPRETATION

1.1 In these conditions:

**BUYER** means the person, firm or company entering into the Contract to purchase the Goods from the Seller;

**CONDITIONS** means the standard terms and conditions of sale set out in this document and (unless the context otherwise requires) includes any special terms and conditions agreed in Writing between the Buyer and the Seller;

**CONTRACT** means the contract for the purchase and sale of the Goods;

**DELIVERY DATE** means the date the Goods are to be collected by the Buyer or if they are to be delivered the time of actual delivery and if the Buyer wrongfully fails to take delivery of the Goods, the date that the Seller notifies the Buyer that the Goods are ready for collection or, as the case may be, the Seller tenders delivery of the Goods;

**GOODS** means the goods (including any installment of the Goods or any parts for them) which the Seller is to supply in accordance with these Conditions; **SELLER** means Specialised Tools And Equipment Ltd - T/A STEL; **WRITING** includes fax, electronic mail and comparable means of communication.

1.2 Any reference in these conditions to any provision of a statute shall be construed as a reference to that provision as amended, re-enacted or extended at the relevant time.

1.3 The headings in these Conditions are for convenience only and shall not affect their interpretation.

### 2. BASIS OF THE CONTRACT

2.1 Save where the Buyer shall place an order with the Seller verbally (in which case it is the Buyer's responsibility to ensure the accuracy of the order), the Seller shall sell and the Buyer shall purchase the Goods in accordance with any written quotation of the Seller which is accepted by the Buyer or any written order of the Buyer and which is accepted by the Seller, subject in either case to these Conditions, which shall govern the Contract to the exclusion of any other terms and conditions subject to which any quotation is accepted or purported to be accepted, or any such order is made or purported to be made by the Buyer.

2.2 The Seller's employees or agents are not authorised to make any representations concerning the Goods unless confirmed by the Seller in Writing. In entering into the Contract the Buyer acknowledges that it does not rely on, and waives any claim for breach of any such representations which are not so confirmed.

2.3 Any advice or recommendation(s) given by the Seller or its employees or agents to the Buyer or its employees or agents as to the storage installation application or use of the Goods which is not confirmed in Writing by the Seller is followed or acted upon entirely at the Buyer's own risk, and accordingly the Seller shall not be liable for any such advice or recommendation which is not so confirmed.

2.4 Any typographical, clerical or other error or omission in any catalogue or other sales literature, quotation, price list, acceptance of order, invoice or other document or information issued by the Seller shall be subject to correction without any liability on the part of the Seller.

2.5 Where any manufacturers names or numbers are mentioned they are for reference purposes only and do not necessarily indicate the source of manufacture nor any connection with the manufacturer.

### 3. ORDERS

3.1 No order submitted by the Buyer shall be accepted or deemed to be accepted by the Seller unless and until confirmed in Writing by the Seller's authorised representative (and the issuing of an invoice by the Seller to the Buyer shall constitute acceptance in Writing).

3.2 The Buyer shall be responsible to the Seller for ensuring the accuracy of the terms of any order and for giving the Seller any necessary information relating to the Contract within a sufficient time to enable the Seller to perform the Contract.

3.3 If the Goods are to be manufactured or any process is to be applied to the Goods, the Seller reserves the right to subcontract any of the manufacturing or other processes to a third party and shall not be liable for any increase in the costs of labour materials or other costs of manufacture, any change of delivery dates quantities or specifications caused by such subcontracting.

3.4 No Contract may be cancelled by the Buyer except with the agreement in Writing of the Seller and on terms that the Buyer shall indemnify the Seller in full against all loss (including loss of profit), costs, damages, charges and expenses.

3.5 The Seller reserves the right to undertake credit references and may suspend performance of the Contract or any other contract with the Buyer if such references are unsatisfactory.

3.6 Each order submitted by the Buyer shall constitute an order capable of acceptance by the Seller. If the Seller agrees that any such order shall constitute an order in circumstances where it is reasonable for the Seller to act in reliance upon such order, such order becomes an order accepted by the Seller and the Buyer shall indemnify and keep the Seller indemnified against all costs, damages, charges and expenses arising from such reliance by the Seller if such order does not become an order capable of acceptance by the Seller.

### 4. PRICE

4.1 The price shall be the Seller's quoted price in Writing, or where no price has been quoted or a quoted price is no longer valid, the price set out on the price list of the Seller prevailing at the date on which the Goods are dispatched. All prices quoted are valid for 30 days or until earlier acceptance by the Buyer, after which time they may be altered by the Seller without giving notice.

4.2 The Seller reserves the right to increase the price to reflect any increase in the cost to the Seller which is due to any factor beyond the Seller's control, any change in delivery or performance dates, quantities or specifications which is requested by the Buyer, or any delay caused by any instructions of the Buyer or failure of the Buyer to give the Seller adequate information or instructions.

4.3 The Seller reserves the right to impose a handling charge of 15% of the net price of the Goods where the Buyer returns the Goods and such return is not due to any fault on the part of the Seller.

4.4 The price is exclusive of any applicable value added tax, which the Buyer shall be additionally liable to pay to the Seller.

4.5 Where Goods are to be delivered otherwise than at the Seller's premises the price is inclusive of all transport, packaging and insurance provided that the order has the following net value;

UK Mainland £200.00

N. Ireland £300.00

Channel Islands £300.00

If the net value of the order is lower than that stated above or the Buyer requires delivery to Southern Ireland or outside of the UK and Channel Islands then the price of the Goods is stated to be exclusive of all transport, packaging and insurance costs and the Buyer shall be liable for the costs of the same.

### 5. TERMS OF PAYMENT

5.1 The Seller shall be entitled to invoice the Buyer for the price including without limitation the VAT, transport, packaging and insurance costs referred to in clauses 4.4 and 4.5 on or at any time after the Delivery Date.

5.2 The Buyer shall pay the price without any deduction or set-off on or before the last day of the month following the Delivery Date and the Seller shall be entitled to recover the price notwithstanding that delivery may not have taken place and the property in the Goods has not passed to the Buyer. The time of payment of the price shall be of the essence of the Contract.

5.3 If the Buyer fails to make any payment on the due date then, without prejudice to any other right or remedy the Seller shall be entitled to:

5.3.1 Suspend all or any further orders to the Buyer made under that or any other contract with the Buyer and in such event the Buyer shall not be released from its obligations to the Seller under that or any other contract or cancel the Contract or any other contract with the Buyer and to claim damages from the Buyer for breach of contract;

5.3.2 Appropriate any payment made by the Buyer to such part of the Contract or the Goods (or the goods supplied under any other contract between the Buyer and the Seller) as the Seller may think fit (notwithstanding any purported appropriation by the Buyer); and

5.3.3 Charge the Buyer interest (both before and after any judgment) on the amount unpaid, at the rate of 4 per cent per annum above Barclays Bank base rate from time to time accruing daily, until payment in full is made; and

5.3.4 Failure to pay on time any part of the debt on or before the due date will render the entire debt as being due immediately from the buyer.

5.4 The Seller may without notice set off any sums from time to time owed to the Buyer in or towards the satisfaction of all and any liabilities of the Buyer to the Seller whether or not under this Contract.

5.5 The Seller shall have a general lien over all goods and property of the Buyer (whether worked on or not) in the possession of the Seller for all unpaid debts due from the Buyer and the Seller reserves the right upon the expiration of fourteen days written notice to dispose of such goods or property and to apply the proceeds of sale (net of costs of sale) towards the payment of such debts.

5.6 Any costs (excluding interest which is covered in section 5.3.3) incurred by the Seller as a result of bounced cheques, or failure to pay on or before the due date will be recoverable from the Buyer.



## 6. DELIVERY

6.1 Unless otherwise agreed in Writing by the Seller, the Goods shall be delivered on the following basis;

UK Mainland To the Buyers place of business N. Ireland To the Buyers place of business

Channel Islands To the Buyers place of business S. Ireland Ex-works  
Export Ex-works

6.2 Where the Goods are delivered to the Buyer's premises the Buyer shall be responsible for unloading the Goods and where the Seller or its employees or agents carry out or assist the Buyer, its employees or agents in such unloading the Buyer shall indemnify and keep indemnified the Seller against all liabilities including without limitation all loss, costs, charges and expenses arising from such unloading.

6.3 Where the Goods are delivered on an ex-works basis the Buyer will take delivery of the Goods within 4 days of the Seller giving it notice that the Goods are ready for delivery.

6.4 Where the Goods are to be delivered to N. Ireland or the Channel Islands, or the Seller has otherwise agreed to deliver the Goods outside the UK Mainland all Goods shall be delivered FOB the air or sea port of shipment and the Seller shall be under no obligation to give notice under s32(3) of the Sale of Goods Act 1979. The Buyer shall be responsible for complying with any legislation or regulations governing the importation of the Goods into the country of destination and for the payment of any duties thereon.

6.5 Any dates quoted for delivery of the Goods are approximate only and the Seller shall not be liable for any delay howsoever caused. Time for delivery shall not be of the essence. If no dates are specified, delivery will be within a reasonable time.

6.6 Where the Goods are to be delivered in installments, each delivery or performance shall constitute a separate contract and failure by the Seller to deliver or perform any one or more of the installments in accordance with these Conditions or any claim by the Buyer in respect of any one or more installments shall not entitle the Buyer to treat the Contract as a whole as repudiated.

6.7 Where the Goods are to be delivered on an ex-works basis the Buyer will provide at its own expense adequate and appropriate equipment and manual labour for loading the Goods.

6.8 Where the Goods to be supplied are ex-stock, the Seller reserves the right to delay delivery of ex-stock items until supplies of such goods are received by the Seller, whereupon the Seller shall deliver such items.

6.9 If the Goods (or any installment are not available on the Delivery Date) for any reason other than any cause beyond the Seller's reasonable control or the Buyer's fault, the Seller shall be liable to the Buyer and the Seller's liability shall be limited to the excess, if any, of the reasonable cost to the Buyer (in the cheapest available market) of similar goods to replace those not delivered over the price of the Goods.

6.10 If the Buyer fails to take delivery of the Goods or fails to give the Seller adequate delivery instructions at the time stated for delivery (otherwise than by reason of any cause beyond the Buyer's reasonable control or by reason of the Seller's fault) then, without prejudice to any other right or remedy available, the Seller may :-

6.10.1 Store the Goods until actual delivery and charge the Buyer for the reasonable cost of storage, including insurance;

6.10.2 After the expiration of 3 months from the Delivery Date dispose of the Goods in such manner as the Seller may determine; and

6.10.3 Suspend any further performance of the services under the Contract or any other contract.

6.11 Shall the Buyer require delivery of Goods at the weekend, the Buyer shall be responsible for and agrees to indemnify and keep indemnified the Seller against any additional delivery costs and expenses resulting from the delivery being at the weekend.

## 7. RISK AND PROPERTY

7.1 Save where clause 6.4 applies risk of damage to or loss of the Goods shall pass to the Buyer on the Delivery Date.

7.2 Notwithstanding the passing of the risk in the Goods or any other provision of these Conditions the property in the Goods shall not pass to the Buyer until the Seller has received in cash or cleared funds payment in full of the price of the Goods and all other goods sold or agreed to be sold by the Seller to the Buyer under any other contract.

7.3 Until such time as the property in the Goods passes to the Buyer, the Buyer shall hold the Goods as the Seller's agent or bailee, and shall keep the Goods separate from those of the Buyer and third parties and properly stored, protected and insured and identified as the Seller's property. Until such time as the property in the Goods passes to the Buyer, the Buyer shall be entitled to resell or use the Goods in the ordinary course of its business, but shall have a fiduciary duty to the Seller to account for the proceeds of sale or otherwise of the Goods.

7.4 Until such time as the property in the Goods passes to the Buyer, the Seller shall be entitled at any time to require the Buyer to deliver up the Goods to the Seller and, if the Buyer fails to do so forthwith, to enter upon any premises of the Buyer or any third party where the Goods are stored and repossess the Goods and for that purpose the Buyer hereby authorises and licences the Seller, its officers, employees and agents to enter upon any land or building upon which the Goods are situated to recover those Goods.

7.5 The Buyer shall not be entitled to or in any way charge by way of security for any indebtedness, any of the Goods which remain the property of the Seller, but if the Buyer does so all moneys owing by the Buyer to the Seller shall without prejudice to any other right or remedy of the Seller forthwith become due and payable.

## 8. WARRANTIES AND LIABILITIES

**THE BUYER'S ATTENTION IS IN PARTICULAR DRAWN TO THE PROVISIONS OF THIS CLAUSE.**

8.1 Subject as expressly provided in these Conditions, all warranties, conditions or other terms implied by statute or common law are excluded to the fullest extent permitted by law.

8.2 Any claim by the Buyer which is based on any defect in the quality, condition or under-delivery of the Goods by more than 5%, whether or not delivery is refused by the Buyer shall be notified to the Seller within 3 days from the Delivery Date or, where the defect or failure was not apparent on reasonable inspection, within a reasonable time after discovery of the defect or failure and in any event within 7 days of discovery. If delivery is not refused, and the Buyer does not so notify the Seller, the Seller shall have no liability for such defect or failure, and the Buyer shall be bound to pay the price as if the Contract had been performed in accordance with its terms.

8.3 Where a valid claim is notified to the Seller in accordance with clause 8.3 and Goods are to be returned to the Seller they must be accompanied by a despatch note quoting the original invoice number within 2 months of the Delivery Date. Goods that are soiled or damaged will not be accepted and acceptance of return by a sales representative does not constitute acceptance by the Seller.

8.4 Where any valid claim in respect of any of the Goods, which is based on any defect in the quality or condition is notified to the Seller and Goods are returned in accordance with these Conditions, the Seller shall be entitled to replace the Goods (or the part in question) free of charge or, at the Seller's sole discretion, refund to the Buyer the price (or a proportionate part of the price) but the Seller shall have no further liability to the Buyer.

8.5 The Seller shall not be liable to the Buyer by reason of any representation, or any implied warranty, condition or other term, or any duty at common law, or under the express terms of the Contract, for any consequential loss or damage (whether for loss of profit, product recall or otherwise), costs, expenses or other claims for compensation whatsoever (whether caused by the negligence of the Seller, its employees or agents or otherwise) which arise out of or in connection with the supply of the Goods and the entire liability of the Seller under or in connection with the Contract shall not exceed the price under the Contract, except as expressly provided in these Conditions.

8.6 The Seller shall not be liable to the Buyer or be deemed to be in breach of the Contract by reason of any delay in performing, any of the Seller's obligations if the delay or failure was due to any cause beyond the Seller's reasonable control.

8.7 Nothing in these Conditions shall exclude or limit the Seller's liability for death or personal injury caused by the Seller's negligence.

## 9. INSOLVENCY OF BUYER

9.1 This clause applies if:

9.1.1 The Buyer makes any voluntary arrangement with its creditors or becomes subject to an administration order (or being an individual or firm) becomes bankrupt or (being a company) goes into liquidation, otherwise than for the purpose of amalgamation or reconstruction; or

9.1.2 An encumbrancer takes possession, or a receiver is appointed, of the Buyer's undertaking or any of its property or assets; or

9.1.3 The Buyer ceases, or threatens to cease, to carry on business; or

9.1.4 The Seller reasonably apprehends that any of the events mentioned above are about to occur in relation to the Buyer and notifies the Buyer accordingly.

9.2 If this clause applies then, without prejudice to any other right or remedy available to the Seller, the Seller shall be entitled to cancel the Contract and/or any further deliveries under the Contract without any liability to the Buyer, and if the Goods have been delivered, but not paid for, the price shall become immediately due and payable.

## 10. GENERAL

10.1 Neither the Buyer nor the Seller shall be entitled to assign the whole or any part of the Contract without the prior written consent of the other provided that the Seller shall be entitled to subcontract the whole or any part of its obligations.

10.2 No waiver by the Seller of any breach of the Contract by the Buyer shall be considered as a waiver of any subsequent breach of the same or any other provision.

10.3 If any provision of these Conditions is held by any competent authority to be invalid or unenforceable in whole or in part the validity of the other provisions of these Conditions and the remainder of the provision in question shall not be affected thereby unless such provision goes to the root of the Contract.

10.4 The Conditions shall constitute the entire agreement in relation to the subject matter and no modification or waiver thereof shall be valid unless made in Writing expressly for the purpose and signed by an authorised officer of the Seller and of the Buyer provided that nothing in these Conditions shall exclude or limit liability for fraud.

10.5 Unless expressly provided in these Conditions, no term of the Contract is enforceable pursuant to the Contracts (Rights of Third Parties) Act 1999 by any person who is not a party to it.

10.6 Unless expressly stated in these conditions time shall not be of the essence in this Contract.

10.7 The Contract shall be governed by the laws of England and the Buyer agrees to submit to the exclusive jurisdiction of the English Courts.



**SERIOUS  
ABOUT  
SERVICE**